

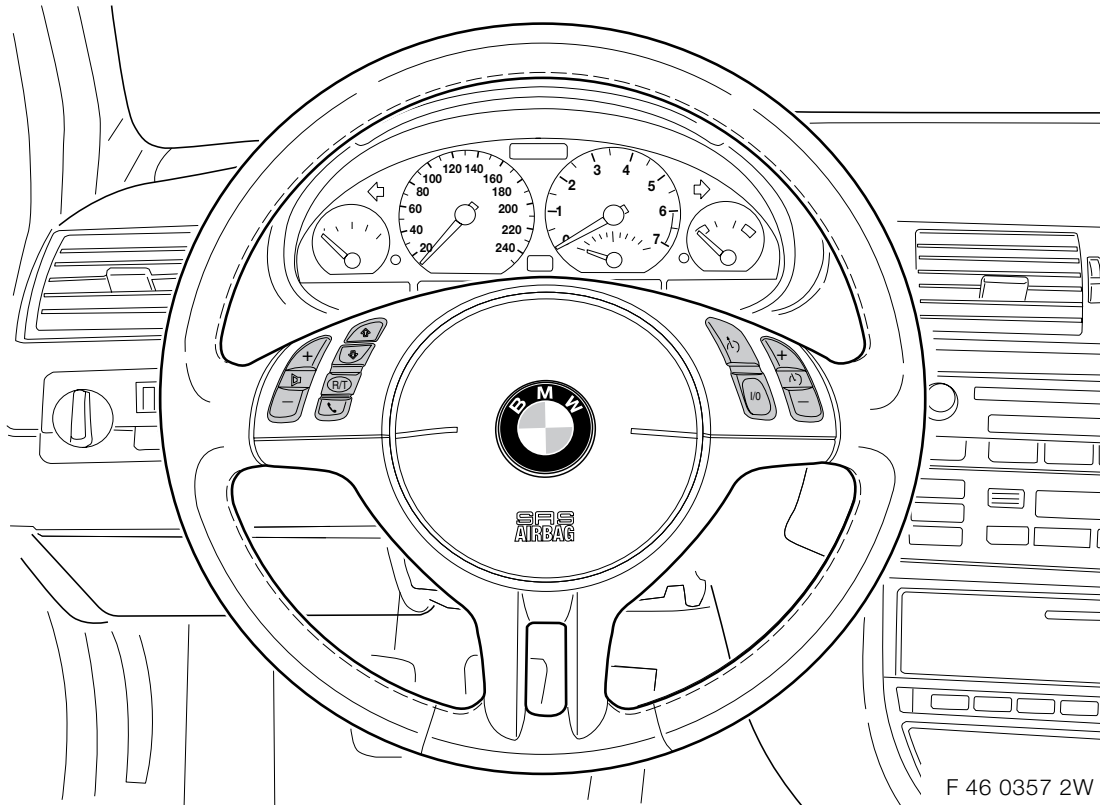

Parts and Accessories Installation Instructions



Multi-functional steering wheel (MFL) / Cruise control (GRA) retrofit kit **Retrofit kit identical to standard equipment for BMW 3 Series Coupé, touring,** **Saloon from 6/00 and Convertible, compact from start of series (E 46/2/3/4/5/C)**

The installation time is approx. 1 hour, but this may vary depending on the condition of the car and the equipment in it.

Retrofit/Installation kit No. 65 71 0 021 159
65 71 0 026 223

Contents

Section	Page
Important information	3
1. Preparations	4
2. MFL/GRA wiring harness connection diagram	5
3. Installation and cabling diagram	6
4. To install and connect the MFL/GRA retrofit wiring harness	7
5. To modify a 3-spoke sport steering wheel	9
6. To install a 3-spoke sport steering wheel	11
7. To install a 4-spoke steering wheel	12
8. Concluding work	13
9. Circuit diagram	14

Important information

The retrofit kit is for use within the BMW dealership organisation only.

Installation information

All work is shown using a left-hand drive vehicle. On RHD cars some work must be completed the opposite way round.

Target group

The target group for these installation instructions is specialist personnel trained on BMW cars with specialist knowledge of vehicle electrical systems.

Work:

All servicing, repair and installation work on BMW cars is completed at your own risk.

All work must be completed using the latest BMW repair manuals and circuit diagrams in a rational order using the prescribed tools (special tools) and observing current health and safety regulations.

Special tools required

Torque wrench

Folding leg (00 9 321)

Crimping pliers (61 9 040)

1. Preparations

	TIS instruction No.
 Refer to the safety instructions for handling components of the airbag system. ◀	32 34 ...
Conduct a brief test	
Disconnect the battery	12 00 ...
The following components must be removed first of all:	
Airbag unit	32 34 020
Steering wheel	32 33 000
Top steering column trim	32 31 020
Release the bottom steering wheel trim	32 31 003
Glove compartment	51 16 350
Pedal trim	51 45 185
Light switch unit	61 31 033
Electrics box cover	

2. MFL/GRA wiring harness connection diagram

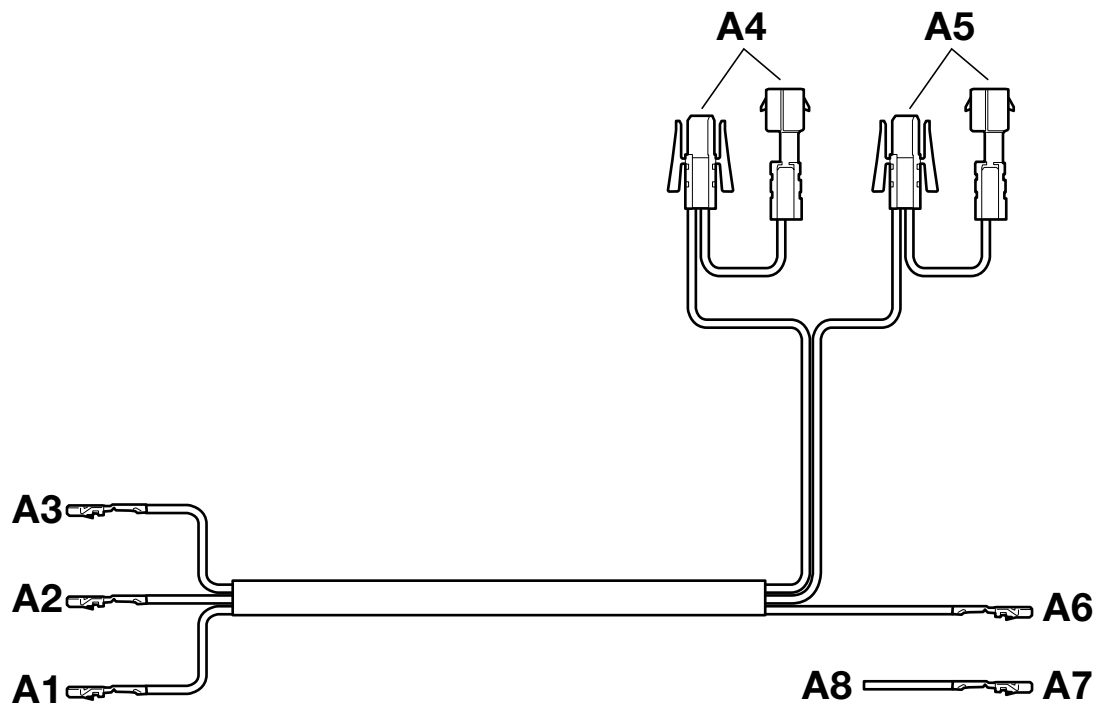

046 0456 Z

Branch	Description	Signal	Cable colour / Cross-section	Connection location in the car	Abbreviation / Slot
A1	Socket contact	DME/DDE	BL/SW 0.35 mm ²	On the steering column switch mounting 10-pin plug GN	X10170 PIN 8
A2	Socket contact	K bus	WS/RT/GE 0.35 mm ²	On the steering column switch mounting 10-pin plug GN	X10170 PIN 9
A3	Socket contact	Terminal R	VI/GE 0.5 mm ²	On the steering column switch mounting 10-pin plug GN	X10170 PIN 10
A4	Twin-lead terminal	Terminal R	VI/GE 0.5 mm ²	On the light switch unit SW 54-pin plug	X12 PIN 27
A5	Twin-lead terminal	K bus	WS/RT/GE 0.35 mm ²	On the light switch unit SW 54-pin plug	X12 PIN 21
A6	Socket contact	DME/DDE	BL/SW 0.35 mm ²	M47 engine before 9/01 only and all N42, M54 and M57 engines On the DME/DDE control module SW 40-pin plug	X60004 PIN 27
A7	Socket contact	DDE	WS 0.35 mm ²	M47TÜ engine after 9/01 only To DDE control module SW 58-pin plug	X60002 PIN 37
A8	Cable branch	DDE	WS 0.35 mm ²	M47TÜ engine after 9/01 only With butt-joint connector to branch A6	---

3. Installation and cabling diagram

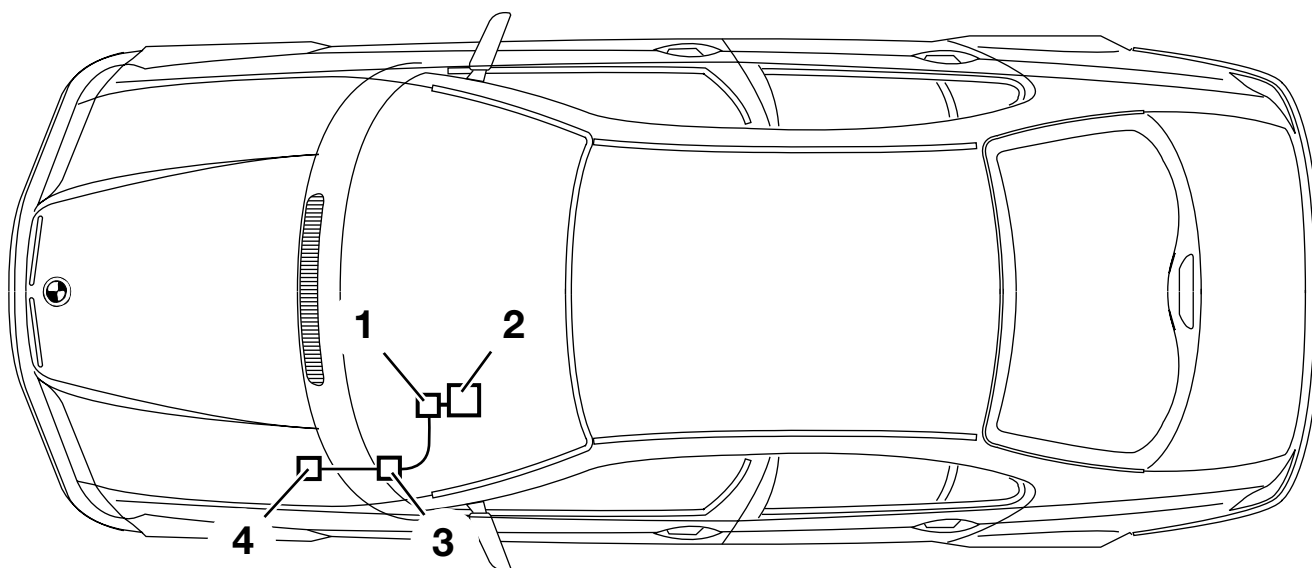

046 0457 Z

Legend

- 1 Steering column switch mounting
- 2 Multi-functional steering wheel
- 3 Light switch unit
- 4 Electrics box

4. To install and connect the MFL/GRA retrofit wiring harness

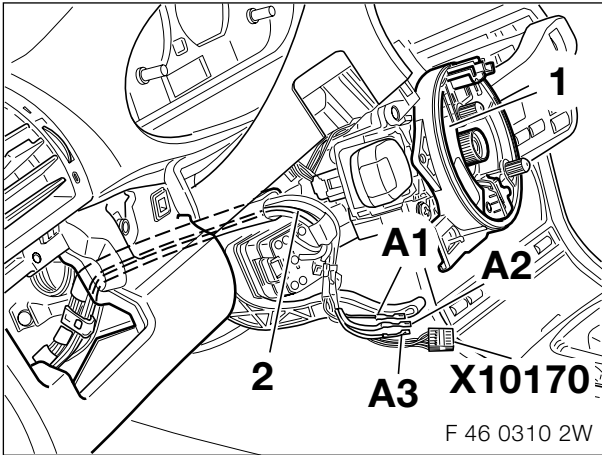

Disconnect and release the green, 10-pin plug **X10170** from the switch mounting (1).

Lay the retrofit wiring harness (2) along the cable guide on the steering column to plug **X10170**.

Connect branches **A1 - A3** as follows to plug **X10170**:

Branch **A1**, BL/SW cable, in PIN 8

Branch **A2**, WS/RT/GE cable, in PIN 9

Branch **A3**, VI/GE cable, in PIN 10

Assemble plug **X10170** again and reconnect it to the switch mounting (1).

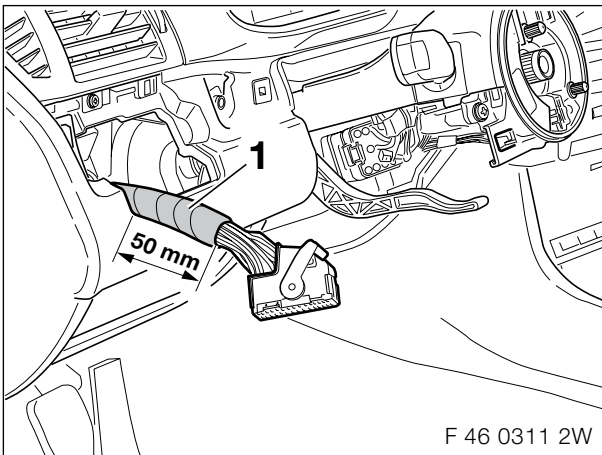

Remove the cable insulation (1) over a length of approx. 50 mm.

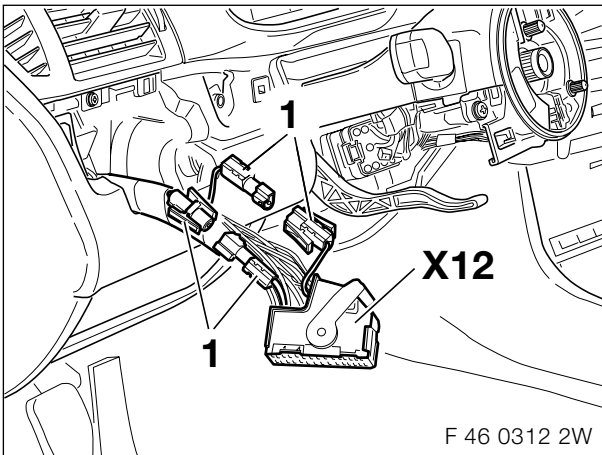

Cut the VI/GE (PIN 27) and WS/RT/GE (PIN 21) cables from plug **X12** approx. 40 mm behind the plug **X12**.

Fit the ends of the cables with a socket/pin contact and insulation casing (1).

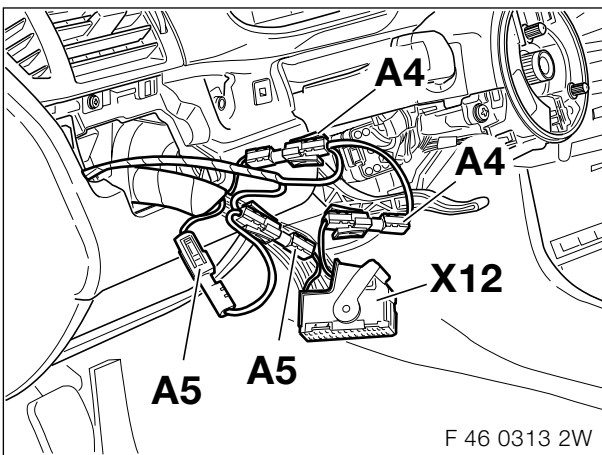

Lay branches **A4 - A5** to plug **X12** and connect to the same colours on the new connections.

4. To install and connect the MFL/GRA retrofit wiring harness

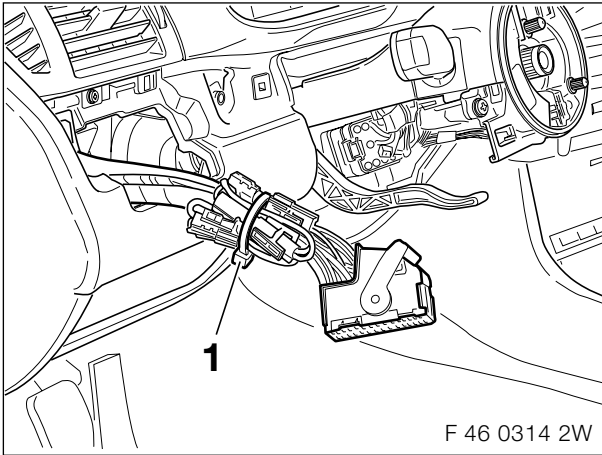

Secure the plug connectors to the wiring harness using cable ties (1).

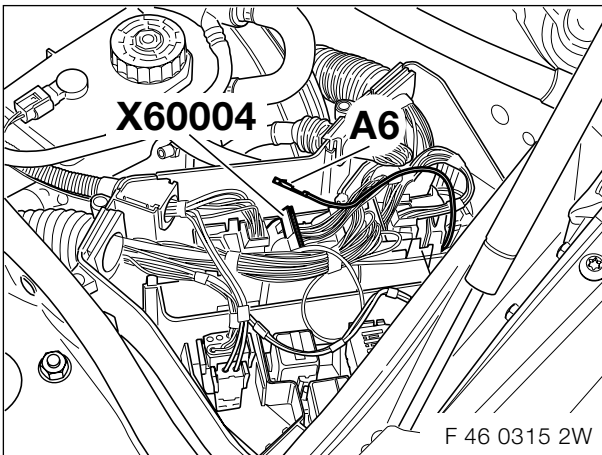

On RHD cars the tied back cable on branch **A6** must be released. Branch **A6** must be laid through the corrugated tube behind the heating/air conditioning unit to the left-hand side of the car and from there into the electrics box. ◀

Lay branch **A6** through the cable passage into the electrics box.

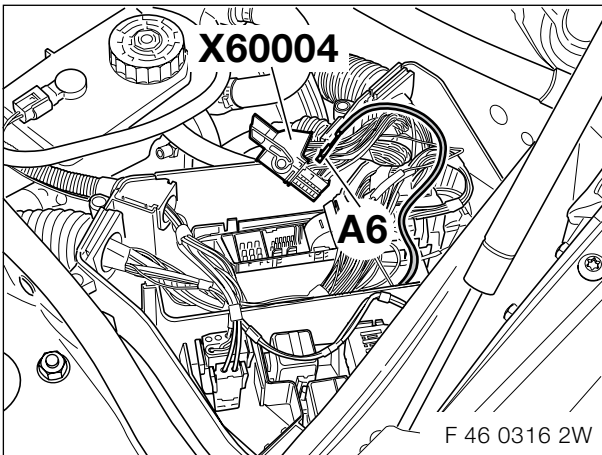

Cars with M47 engines before 9/01 only and all N42, M54 and M57 engines

Disconnect the black 40-pin plug **X60004** from the DME/DDE control module and release them.

Connect branch **A6** BL/SW cable, to PIN 27 in plug **X60004**.

Reconnect plug **X60004** to the DME/DDE control module.

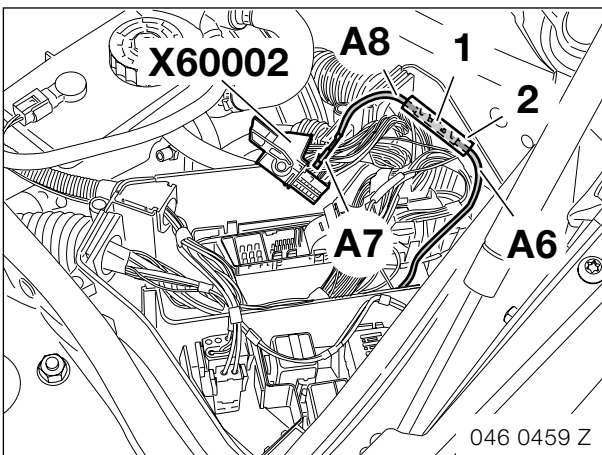

Cars with M47TÜ engine after 9/01 only

Cut the socket contact off branch **A6**.

Connect branch **A8** to the open cable end on branch **A6** using a butt-joint connector (1) and shrink hose (2).

Disconnect the black 58-pin plug **X60002** from the DDE control module and release it.

Connect branch **A7** to PIN 37 in plug **X60002**.

Reconnect plug **X60002** to the DDE control module.

5. To modify a 3-spoke sport steering wheel

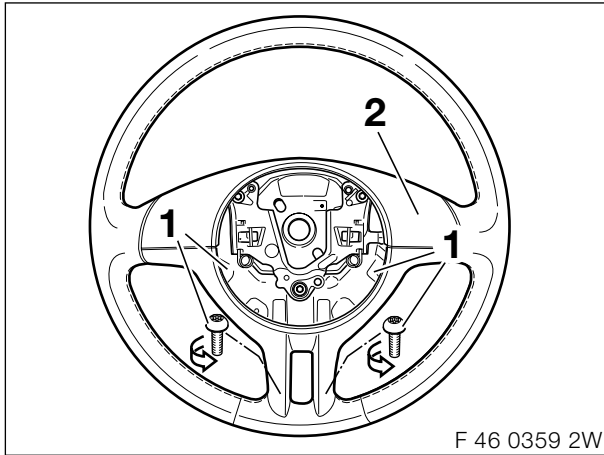

Unscrew the Torx bolts (1) and remove the cover cap (2).

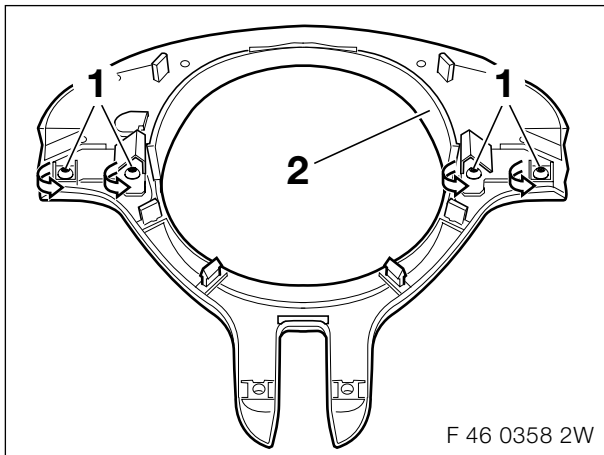

Unscrew the Torx bolts (1) and remove the top section (2).

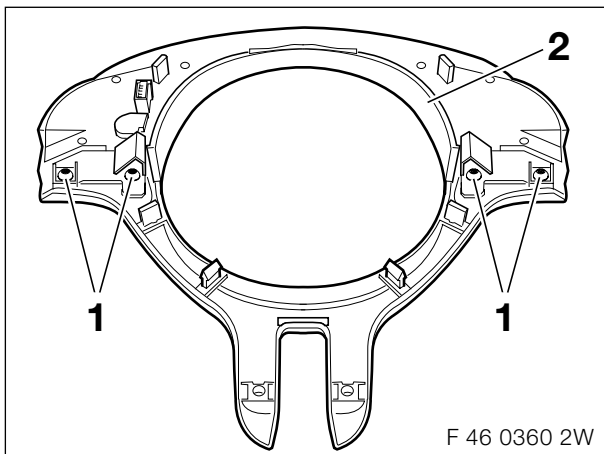

Insert the switch unit (1) and secure it with Torx bolts (2).

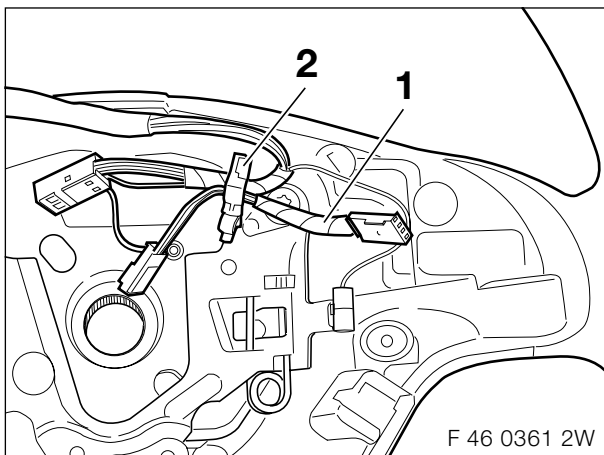

Place the connection cable (1) from the installation kit into the cable tie (2).

5. To modify a 3-spoke sport steering wheel

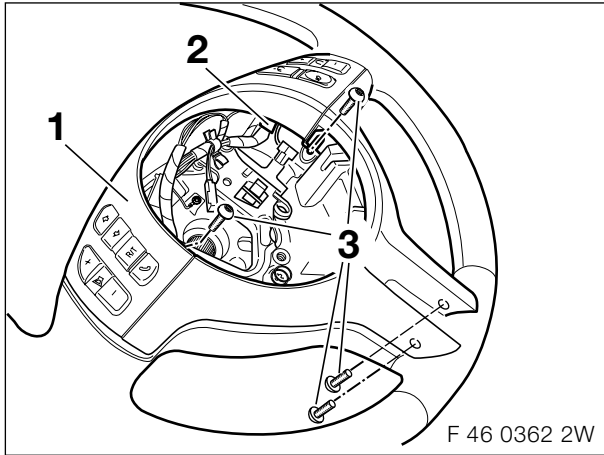

Place the cover cap (1) and switch unit on to the steering wheel.

Connect the connection cable (2) to the switch unit.

Secure the cover cap (1) to the steering wheel using Torx bolts (3).

6. To install a 3-spoke sport steering wheel

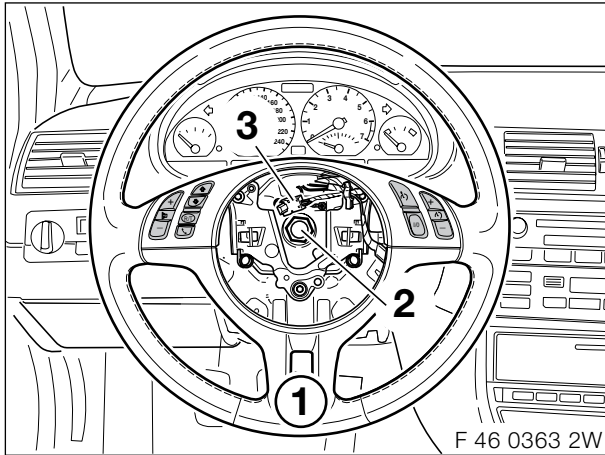

Fit the sports steering wheel (1) and tighten the screws (2) with a torque of 63 Nm.

Connect the plug (3) to the switch mounting.

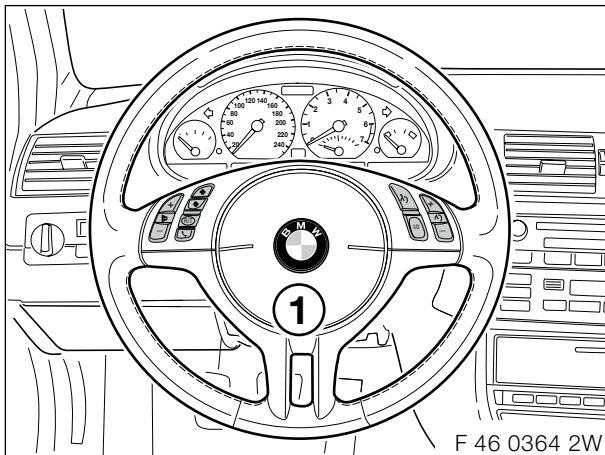

Install the existing airbag unit (1).

7. To install a 4-spoke steering wheel

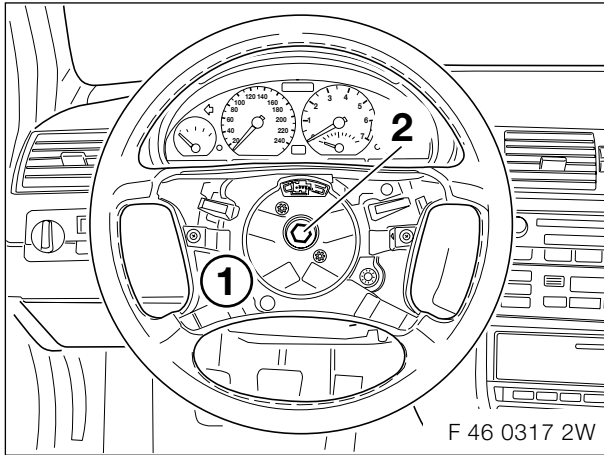

Fit the existing 4-spoke steering wheel (1) and tighten the screws (2) with a torque of 63 Nm.

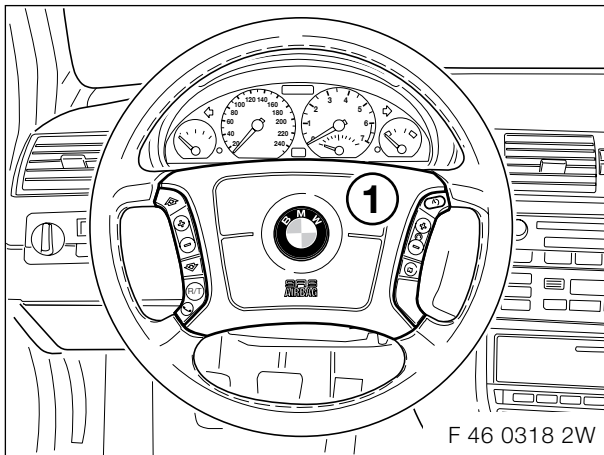

Install the airbag unit with the multi-functional steering wheel buttons (1).

Tighten the securing screws for the airbag unit with a torque of 8 Nm.

8. Concluding work

- This MFL/GRA retrofit kit does not require coding.
- Assemble the car following the instructions to dismantle it in reverse order.
- Conduct a brief test.
- Conduct a function test (the operating instructions for the MFL/GRA retrofit kit are set out in the car or radio owner's manual).

9. Circuit diagram

Cars with M47 engines before 9/01 only and all N42, M54 and M57 engines

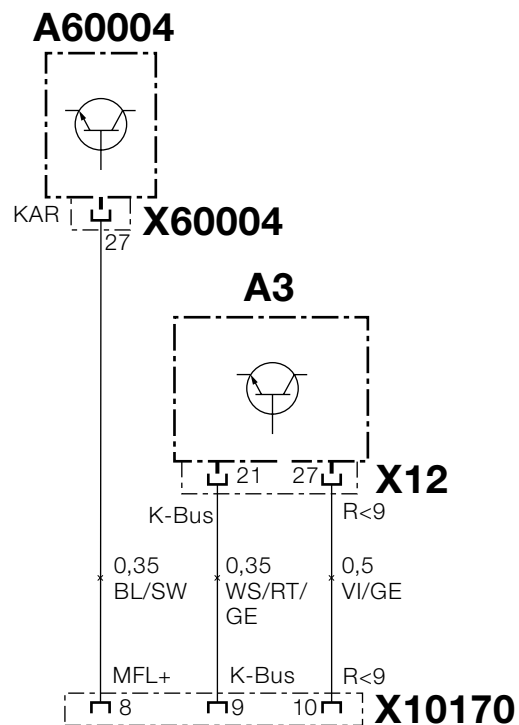

F 46 0321 2W

Legend

A3	Light switch centre control module
A60004	DME/DDE control module
X12	SW 54-pin plug on the light switch centre
X10170	10-pin plug GN on the steering column switch
X60004	SW 40-pin plug on the DME/DDE control module

Cable colours

RT	red
SW	black
BL	blue
GE	yellow
VI	violet
WS	white

9. Circuit diagram

Cars with M47TÜ engine after 9/01 only

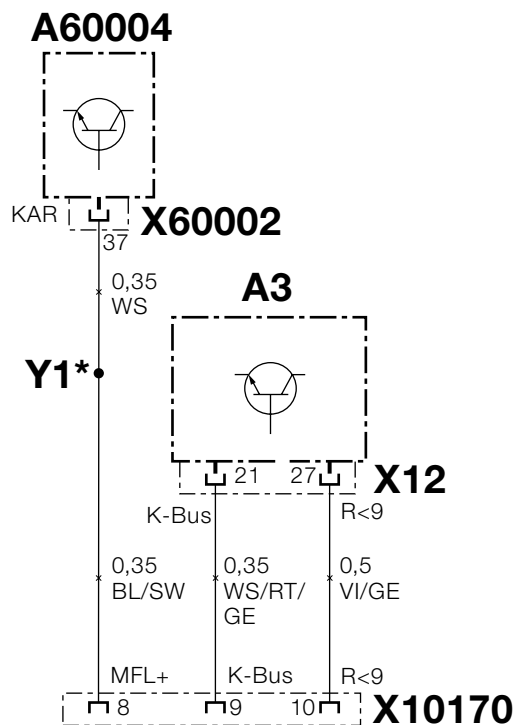

046 0458 Z

Legend

A3	Light switch centre control module
A60004	DME/DDE control module
X12	SW 54-pin plug on the light switch centre
X10170	10-pin plug GN on the steering column switch
X60002	SW 58-pin plug on the DDE control module
Y1	Butt joint connector

All the designations marked with an asterisk (*) apply only to these installation instructions or these circuit diagrams.

Cable colours

RT	red
SW	black
BL	blue
GE	yellow
VI	violet
WS	white