



LCHA Roundup

www.larimerhorseman.org

LARIMER COUNTY HORSEMAN'S ASSOCIATION

April, 2010

What is Teamwork?

We all want good relationships with our horses, but the type of relationship we want can vary. To some, horses are strictly pets, while others view them as recreation companions, competition partners, even work tools. One common thread among them all is teamwork. At the April 5th Program meeting, trainer Kristin Schuett will work with owners and their horses to improve teamwork on the ground and in the saddle.

The first step will be to determine how well the horses respect their owners. Using simple groundwork exercises, Kristin will show how to evaluate your own horse's attitude and then how to improve respect to keep you safe. Next, the evaluation process will continue for tacking up, mounting, and riding. More strategies will be provided for improving teamwork at each of these stages.

If you are interested in bringing your horse to the demo, contact Kristin at kristin@lpbroadband.net.

The Program meeting will start at 7:00 pm and take place at Gilnocky Equestrian Center in east Berthoud. Please dress warmly and bring a chair.

Spring Tack Sale and Trailer Challenge

Below are more details about the LCHA Spring Tack Sale and Trailer Challenge on Saturday, May 8th at Gilnocky Equestrian Center in Berthoud:

TACK SALE

All sale items must be tagged with the first initial and last name of the seller, a one- or two-word description of the item, and the price. Free tags will be available at our program meetings. Each item must be clean and in good repair. Sale volunteers will determine whether an item is in saleable condition. Items that don't sell can be

returned to the seller within three days or stored until the next sale.

If you want to drop off tack at Gilnocky before the day of the sale, contact Kristin at kristin@lpbroadband.net or 443-2758 to schedule a time. On the day of the sale, tack will be accepted 9:00 AM to 11:30 AM. The sale runs 12:00 to 3:00 PM in the indoor arena. No early birds please; the volunteers need time to set up.

After the sale, a check for 90% of the proceeds will be mailed to each seller.

Please encourage your friends to attend the sale for some good bargains and to help support the club.

TRAILER CHALLENGE

To register for this event, e-mail Kristin at kristin@lpbroadband.net and provide the following information:

- Name and cell phone number for each driver
- Which part of the event to attend (Skills Stations, Obstacle Course Contest, or both)

In this month's issue . . .

What is Teamwork?	page 1
Spring Tack Sale and Trailer Challenge	page 1
Directions to Meetings at Gilnocky Equestrian Center	page 3
USRider Equestrian Motor Plan	page 3
Temporary Shelter	page 5
Horsin' Around in Northern Colorado	page 5
2010 LCHA Membership Drive and Awards Program	page 6
Newsletter: Paper or Website?	page 8
Trail Crew Leader Training	page 8
Calendar of Events	page 9
CLASSIFIED ADS	page 12

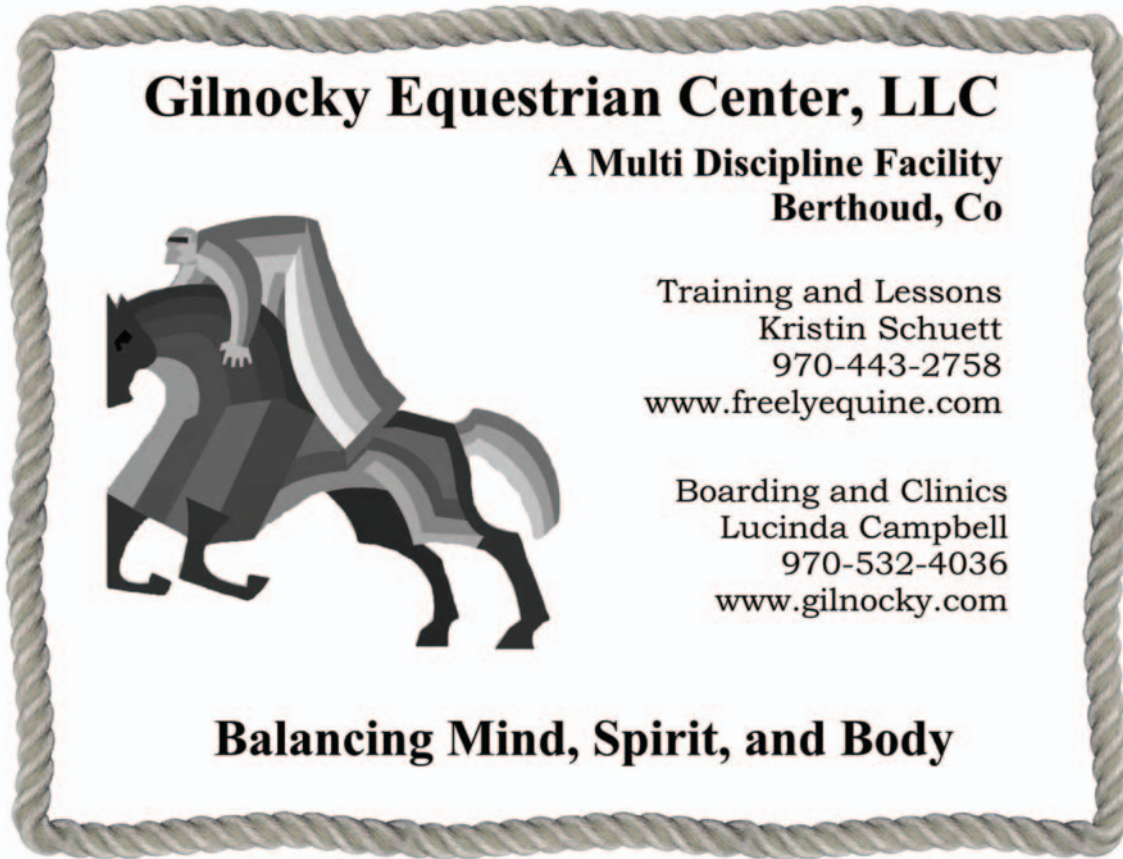

Gilnocky Equestrian Center, LLC
A Multi Discipline Facility
Berthoud, Co



Training and Lessons
Kristin Schuett
970-443-2758
www.freelyequine.com

Boarding and Clinics
Lucinda Campbell
970-532-4036
www.gilnocky.com

Balancing Mind, Spirit, and Body

Paid Advertising

Tack Sale and Trailer Challenge – Continued

- Preferred arrival time (11:00 – noon, noon – 1:00, or 1:00 – 2:00)
- Bringing own trailer or need to borrow one

Entry fee is \$5 per driver to participate in any part of the event, which is open to the public.

Skills stations will provide individual coaching and practice on specific skills, such as hitching up, backing in a straight line using mirrors only, backing into a parking spot, or backing around a curve.

The Obstacle Course Contest will feature three obstacles. Instructions, time limit, and scoring for each obstacle will be available at the event. Men and women will compete in separate divisions, with a prize for the winner in each division.

NOTE: In case of rain, the Trailer Challenge will be rescheduled for May 15th.

Kristin Schuett

Directions to Meetings at Gilnocky Equestrian Center

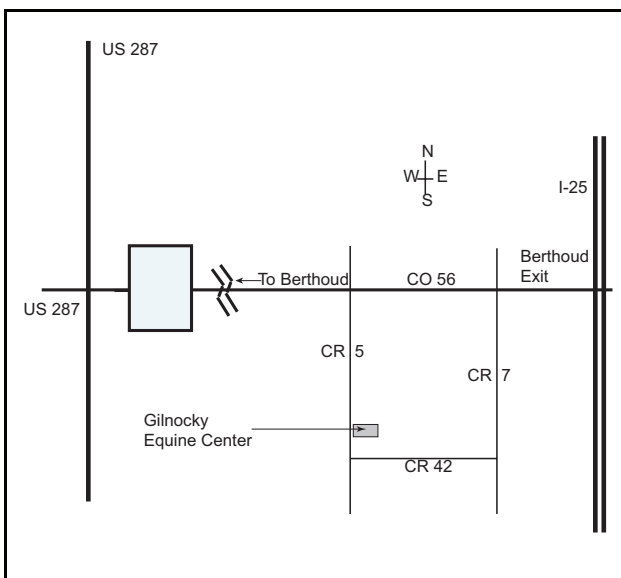

From North, South, or East:

- Take I-25 to the Berthoud exit (Colorado 56).
- Follow CO 56 east about 2 miles to County Road (CR) 5.

- Turn left (south) onto CR 5.
- Follow CR 5 about 1/2 mile. Gilnocky Equestrian Center is on the left (east) side of the road.

From West or South:

- Take US 287 to CO 56.
- Go east on CO 56 through Berthoud.
- From “downtow” Berthoud, follow CO 56 about 3 miles to County Road (CR) 5.
- Turn right (south) onto CR 5.
- Follow CR 5 about 1/2 mile. Gilnocky Equestrian Center is on the left (east) side of the road.

Note: Two driveways enter Gilnocky Equestrian Center. Use the second driveway, and then park in the small area between the arena and the road. If that area is full, follow the second driveway until you find a parking space near the back of the arena.

USRider Equestrian Motor Plan

I have recently stumbled upon a different Automotive Club similar to AAA that also assists with horse trailers in the event of an accident or breakdown on the highway. AAA does not help with horse trailers let alone the horses inside.

I have often wondered what would happen to my horses if my truck breaks down on the road while I am driving through the middle of Nowhere. Maybe you have as well. There is a Motor Plan available to horse enthusiasts that might be for you. (I am not a sales rep for this company! I just feel like I found something that others might benefit from.)

USRider Equestrian Motor Plan (www.usrider.org) will assist with simple things like the need for a locksmith, fuel delivery, flat tire, etc. but it will also offer horse trailer service and towing, emergency trip interruption veterinary service, and stabling locator along with many other benefits similar to what you might expect of a motor plan like AAA (hotel discounts, etc). The cost is a little more, but the peace of mind you have while on the road just might make it worth it for you. I have heard of many horse folks who frequently travel cross country with their horses who been very impressed with their service when needed. It is one of those things that you hope you never need, but will be glad you have it when you do!

Check it out.

Silja Knoll

Early Bird Specials !

2010 Dates



April 10 & 11 **Trail/Horsemanship**
Prepare yourself and horse for the trail riding season.



May 8 & 9 **Gaited Horse**
Understand, Feel, and Know the many soft gaits of the Gaited horse. This clinic is for the rider and their horse.



May 15 & 16 **Riding Together**
This clinic is for Gaited Horse Riders and friends riding Non-Gaited Horses.

June 5 & 6 **Trail/Horsemanship**



June 19 & 20 **Horsemanship/Trail Ride**

Early Bird Special **Take 20% off the clinic price.**
Clinic must be paid in full before March 10th, 2010.

If you missed the Early Bird discount you can still have a good saving.

Little Bird Special **Take 10% off the clinic price.**
Clinic must be paid in full before March 30th, 2010

Each clinic is \$225.00 per rider and horse. Auditors \$20.00

We enjoy a gentle approach, commonly referred to as Natural Horsemanship, and the principles Sally Swift shares in her books *Centered Riding* and *Centered Riding 2: Further Exploration*.



Mountain Magic Ranch LLC
Joe and Kim Andrews
101 South County Road 29
Loveland, CO 80537
970-613-012
www.mountainmagicranch.com



Temporary Shelter

On March 18, looking north from her property, Kim Andrews saw smoke. The first fire of the season was on county road 29 north of US 34. The fire department put it out, but this is why LCHA and NC BCH have begun a joint project called Temporary Shelter for Disaster-Threatened Horses.

Besides the Andrews and their 30 horses, we have other members who live on county road 29. The Temporary Shelter Committee will match members who need to evacuate before a disaster with members who live in safe areas.

If you could provide temporary shelter, please fill out and send in a Provider Form.

If you need shelter for your horses, please call the committee before the County orders evacuation and get out early. The forms will be available at meetings and on the LCHA website. Read the Checklist for Evacuees, post it on your refrigerator, and get ready – Fire Season has started!

Bonnie Templeton

Horsin' Around in Northern Colorado

A List of Horse Events in the Region

- April 3 10AM - 1:30PM
 - April 25 10AM - 1:30PM
 - May 8 10AM - 1:30PM
 - May 23 10AM - 1:30PM
 - June 5 9AM - 12:30PM
 - June 19 9AM - 12:30PM
 - July 10 9AM - 12:30PM
 - July 24 9AM - 10:30PM
 - Aug. 7 9AM - 12:30PM
 - Aug. 21 9AM - 12:30PM
 - Aug. 21 9AM - 12:30PM
-
- April 10 & 11, Trail/Horsemanship
 - May 8 & 9, Gaited Horse
 - May 15 & 16, Riding Together
 - June 5 & 6, Trail/Horsemanship
 - June 19 & 20, Horsemanship & Trail Ride

Trail Obstacle Clinic,
Marty Marten
720-494-9898,
jodymarken@hotmail.com
or www.martymarten.com

Clinics by Joe and Kim
Andrews
613-0121

LCHA Roundup is a newsletter of the Larimer County Horseman's Association (LCHA), P.O. Box 270375, Fort Collins, CO 80527-0375.

*Editor: Hugh Templeton, 970-622-0982
hught@lpbroadband.net*

The LCHA Board of Directors:

- President, Jillian L'Ecyer..... 970-568-9526*
- Vice President, Ted Newport..... 970-397-9591*
- Secretary, Susan Kurzweil..... 970-663-6738*
- Treasurer Gary York..... '970-203-0144*

Committee Managers and Members at Large:

- Sija Knoll, Trail Rides..... 970-402-5104*
- Keith Jacobson, Liaison to County Agencies..... 970-391-1838*
- Kim Andrews, Resolution Committee..... 970-613-0121*
- TJ Newport, Web Master..... 970-397-6986*
- Kristin Schuett, Special Events Coordinator..... 970-443-2758*
- Hugh Templeton, Emergency Evacuation..... 970-622-0982*
- Membership.....*
- Matt Covey, At Large..... 970-227-1447*
- Ted Newport, Business Membership..... 970-397-9591*
- Bonnie Robinson, Program..... 970-215-1142*
- Bonnie Templeton, At Large..... 970-622-0982*
- Mike Triplett, Trail Maintenance Coordinator..... 970-631-7292*
- Darla Hollingshead, At Large..... 970-532-3872*

LCHA Roundup thanks the following persons for their contributions:

Karen Bever— preparing the newsletter for mailing.

If you have ideas, comments, or questions about LCHA, horses, the horse industry in Larimer County, or this newsletter, send them to the editor.

2010 LCHA Membership Drive and Awards Program

Starting March 1st, LCHA will begin the 2010 membership drive *and* awards program. This is an exciting way for all of us to increase the membership of the club AND earn LCHA caps, tee shirts, sweatshirts, and jackets. Our goal is to grow by twenty-five percent during the membership drive.

To participate,

- Print or photocopy the membership form on the next page
- PRINT YOUR NAME on the SPONSOR line.
- Go out and promote LCHA!

Be creative in your approach to promoting LCHA. You don't even need to know the people you sponsor; we will keep track of them for you. Place application forms at boarding facilities, horse businesses, or other place where horse people gather. Use your imagination! And please have permission to leave applications.

LCHA will tally membership applications that are received **with annual dues attached** from March 1st through May 31st. You will be given credit for each NEW MEMBERSHIP application identifying you as the SPONSOR. In June we will tally the applications and credit you with those applications bearing your name as the SPONSOR. The garments you earn will be presented at the Annual Club meeting and awards picnic in June.

LCHA club merchandise garments will be awarded on the following basis:

- Sponsor Two new memberships and you earn a LCHA Baseball Cap OR Tee Shirt.
- Sponsor Four new memberships and you earn a LCHA Sweatshirt.
- Sponsor Six new memberships and you earn a LCHA Cap OR Tee Shirt AND a Sweatshirt.
- Sponsor Eight new membership and you will earn an LCHA Club Jacket.

If you sponsor more members we will award a mix of items appropriate to the memberships received.

This is a membership building promotion, so your renewal application does not count towards awards, but we sure do appreciate your renewing! There is a difference between a member and a membership. An

individual membership counts as one, as does a new family or business membership. It isn't the number of people listed on the application that count toward awards; it is the application that counts. Memberships will be effective June 1st 2010 through May 31st 2011. If members wish to become members immediately they can add \$2.00 per month for March, April and May of this year to the check accompanying the application form.

Thank you in advance for your efforts to make our club grow.

Keith Jacobson

***Please Join the
Larimer County Horseman's Association***

LCHA helps secure our equine presence in the county and we have fun too. We offer trail rides, special events, parade rides, clinics with local trainers, a monthly newsletter, programs and more! You will also meet the nicest horse folks around, people just like you!

Application for LCHA Membership

Name (s): _____

Email address: _____

Address: _____

City: _____ State: _____ Zip: _____

Phone: _____ Work Phone: _____

Newsletter preference. 1 Paper 1 Electronic (saves resources)

Sponsor Name _____ This sponsor will earn club prizes for your membership, so please support them by using this application.

Membership type. (Circle one)

Individual \$24.00 Family \$36.00 Business \$40.00 (includes business listing)

The club membership year is *June 1 to May 31*. For immediate membership add \$2.00 per month for March, April, & May.

Paid by: Cash Check # _____ Please do not mail cash!

Make your check payable to: Larimer County Horseman's Association OR LCHA

Mail to:

Larimer County Horseman's Association
P.O. Box 270375
Fort Collins, CO 80527-0375

Need more info? Go to; www.larimerhorseman.org or call **970-391-1838**

Newsletter: Paper or Website?

More than 40 members have notified me that they can access the newsletter on the LCHA website. As the newsletter is published, I will send a notification email to each of them including a link to take them directly to the web page that contains the latest *LCHA Roundup* edition.

Please let me know if the web newsletter will work for you, or please let me know if the web newsletter DOES NOT work for you. For anyone who needs a paper copy,

we will still print and mail your newsletter to you, but we have to know your preference.

So, please, if you have not notified me, send me an email to templetb@gmail.com or fill out and mail the form below. I want to be sure you are getting your newsletter.

Bonnie Templeton

970-622-0982

templetb@gmail.com

Check one

	I am able to access the Web Newsletter. Please save the stamps and discontinue my printed copy.
	I have internet access, but my connection is dial-up, or for some other reason, I cannot use the web newsletter at this time. Please continue to send me a printed copy.
	I do not have internet access. Please continue to send me a printed copy.
Name:	
Addr:	
Email:	
Phone	

Please detach the form and send it to this address:
Larimer County Horseman's Association, PO Box
270375, Fort Collins, CO 80527

Trail Crew Leader Training

A trail crew leader plans, assists, and educates trail maintenance volunteers in keeping trails safe and enjoyable for all. Larimer County Horseman's Association (LCHA) currently maintains three trails:

- Lion Gulch (on US 36 about 7 miles from Estes Park)
- Mill Creek (in Horsetooth Mountain Park)
- West Ridge (in Horsetooth Mountain Park)

The trail crew leader greets all volunteers as they arrive, gives a tool safety demonstration, and leads the crew(s) onto the trail to locate spots that need care. The

leader then demonstrates how to do the work necessary to repair the trail, and helps volunteers to understand not only what to do, but also why to do it.

And how does the trail crew leader know the what, why, and how of trail maintenance? The USDA Forest Service offers trail crew leader training each year. Here is information for this year's trail crew leader training:

When:

April 28, from 6 to 9 PM,

AND

May 1, from 8 AM to 3 PM

Where:

The Thursday night session is in the building at 2150

Centre Avenue, Building E, Fort Collins.
The Saturday session meets at 2150 Centre Avenue, Building E, Fort Collins, but the carpools to a Forest Service trail to get hands-on training.

This year's training will include a short section on weed ID/ecology/eradication.

RSVP is required. Email Kristy Wumkes at: kwumkes@fs.fed.us

The training is cordial and thorough, and ends with a barbecue. Everyone has a good time, and learns a lot about trail maintenance.

LCHA has had as many as 10 trail crew leaders. However, due to a variety of circumstances, few remain active. We need more trail crew leaders. Also, if you are a trail crew leader who has not been active recently, and if you would like to get active again, consider attending the training. Some things have changed, and you will probably want to know about them.

Hugh Templeton

Calendar of Events

The Trail Ride Coordinator is Silja Knoll (970-402-5104). If you would like to suggest a trail ride location, or if you would like to lead a trail ride, call Silja.

Sign In

If you intend to participate in a trail ride, please notify the ride leader(s):

For A Trail Ride On ...	Notify the Ride Leader(s) by ...
Saturday	Wednesday evening
Sunday	Thursday evening

For any trail ride, be ready to ride at the time shown on this schedule, unless otherwise noted. There is a \$3 fee for non-members.

Events in 2010

Date	Day	Event	Location	Contact	Time
April 5	Mon	Horse Trainer Panel - Your Questions, Trainers' Answers, Paul Esh - Unity With Horses Sean Davies - Colorado Reinsman Kristin Shuett - Freely Equine Steve/Amy LeSatz - Bridle Bit	McKee Building The Ranch	Bonnie Robinson	7 PM to 9 PM
May 3	Mon	What Is Teamwork? Kristin Schuett (a live demo)	Gilnocky Equestrian Center	Bonnie Robinson	7 PM to 9 PM
May 8	Sat	Tack Sale and Trailer Challenge	Gilnocky Equestrian Center	Kristin Schuett	Tack Sale – 12 to 3 PM Trailer Challenge – 11 AM to 3 PM
June 5	Sat	Ride in Berthoud Days Parade	Berthoud	Jillian L'Ecuyer	TBA
June 19	Sat	Training Event	Kay Thomson's arena	Kay Thomson	Ready to ride at 9:00 AM

Events in 2010 (continued)

Date	Day	Event	Location	Contact	Time
June 19	Sat	Annual Meeting	Kay Thomson's	Jillian L'Ecuyer	1:00 PM
Aug 4		Ride in Larimer County Parade	Loveland	Darla Hollingshead	TBA
Aug 6 - 10		Larimer County Fair	The Ranch	TBA	TBA
Aug 20 - 22	Fri, Sat, and Sun	LCHA Camping	Jack's Gulch	Gary York	TBA
Aug 28	Sat	Fall Clinics	Circle Back Farm, Loveland	Kristin Schuett	TBA
Dec 4	Sat	Christmas Caroling on Horseback	Berthoud	Kay Thomson	Noon
Dec 5	Sun	LCHA Christmas Party	TBA	Susan Kurzweil	TBA

Trail Maintenance Schedule for 2010

Day/Date	Trail	Arrive
Sat/ Apr 24	Mill Creek	9:00 AM
Sat/ May 22	Mill Creek	9:00 AM
Sat/ June 5	Lion Gulch Hugh Templeton, 970-622-0982	8:30 AM
Sat/ June 26	Mill Creek	9:00 AM
Sat/ July 17	Lion Gulch Hugh Templeton, 970-622-0982	8:30 AM
Sat/ Aug 21	West Ridge	9:00 AM
Sat/ Sept 18	West Ridge	9:00 AM
Sat/ Sept 25	Lion Gulch Hugh Templeton, 970-622-0982	8:30 AM
Sat/ Oct 9	West Ridge	9:00 AM

LCHA is currently seeking persons who will lead trail maintenance trips on Mill Creek and West Ridge trails. Both are in Horsetooth Mountain Park.

Trail Rides for 2010

Date	Day	Location	Leader	Pace	Limit	Arr	Ride
March							

Trail Rides for 2010 (continued)

Date	Day	Location	Leader	Pace	Limit	Arr	Ride
Mar 27	Sat	Pineridge LCHA members only	Bonnie Robinson 970-215-1142	W/T	6 riders	10:30	11:00
April							
Apr 11	Sun	Bobcat Ridge LCHA members only	Susan Kurzweil 970-663-6738	W	6 riders	10:30	11:00
Apr 16	Fri	Eagles Nest LCHA members only	Susan Kurzweil 970-663-6738	W/T	8 riders	10:30	11:00
Apr 25	Sun	Bobcat Ridge LCHA members only	Susan Kurzweil 970-663-6738	W/T	6 riders	10:30	11:00
May							
May 6	Thurs	Bobcat Ridge LCHA members only	Joy York 970-663-0133	W	6 riders		
May 8	Sat	Soderburg LCHA members only	Lynn Dexter	W/T/C		10:30	11:00
May 12	Wed	Bobcat Ridge LCHA members only	Joy York 970-663-0133	W	6 riders		
May 16	Sun	Lory State Park LCHA members only	Bonnie Robinson 970-215-1142	Gaited	6 riders	10:00	10:30
May 18	Tues	Bobcat Ridge LCHA members only	Joy York 970-663-0133	W	6 riders		
May 29	Sat	Mt Margaret LCHA members only	Bonnie Robinson 970-215-1142	W/T/C	no limit	10:00	10:30
June							
June 6	Sun	Soapstone LCHA members only	Pat Carey 970-224-4532	W/T	6 riders	10:00	10:30
June 12	Sat	Bobcat Ridge LCHA members only	Bonnie Robinson 970-215-1142	W/T	6 riders	9:30	10:00
June 27	Sun	Crozier Mountain LCHA members only	Susan Kurzweil 970-663-6738	W/T	3 trucks/ trailers	9:30	10:00
July							
July 10	Sat	Pineridge LCHA members only	Bonnie Robinson 970-215-1142	W/T	6 riders	10:00	10:30
July 18	Sun	Molly Lake LCHA members only	Pat Carey 970-224-4532	W/T	8 riders	10:00	10:30
July 28	Wed	Lory State Park, South Parking Lot LCHA members only	Pat Carey 970-224-4532	W	no limit	4:00 PM	4:30 PM
August							
Aug 1	Sun	Lone Pine, Lower Road LCHA members only Reminder: You must have a Colorado Department of Wildlife Habitat Stamp to participate in this ride.	TJ Newport 970-397-6986	W/T	6 riders	9:30	10:00
Aug 15	Sun	Hermit Park LCHA members only	Pat Carey 970-224-4532	W/T	6 riders	10:00	10:30

Trail Rides for 2010 (continued)

Date	Day	Location	Leader	Pace	Limit	Arr	Ride
September							
Sept 11	Sat	Soapstone, Red Mountain Trail LCHA members only	Ted Newport 970-397-9591	W/T/C	6 riders	8:30	9:00
Sept 12	Sun	Red Mountain LCHA members only	Pat Carey 970-224-4532	W/T	6 riders	10:00	10:30
Sept 19	Sun	Mt Margaret LCHA members only	Bonnie Robinson 970-215-1142	W/T	no limit	10:30	11:00
Sept 26	Sun	North Fork Trail out of Dunraven Glade: Fall Colors LCHA members only	TJ Newport 970-397-6986	W	6 riders or 12 riders	9:30	10:00
October							
Oct 2	Sat	Crozier Mountain LCHA members only	Susan Kurzweil 663-6738	W/T	3 trucks/ trailers	9:30	10:00
Oct 10	Sun	Eagles Nest LCHA members only	Pat Carey 970-224-4532	W/T	6 riders	9:00	9:30
December							
Dec 4	Sat	Christmas Caroling on Horseback, Berthoud This event is open to the public.	Kay Thomson 970-532-2443	W	no limit	noon	12:45

W = Walk; T = Trot; C = Canter

Ride Limitations

Some LCHA trail rides have been large. When large numbers of people sign up for trial rides, the ride leader may take one or more of the following actions:

- Encourage horse pooling (if parking space is an issue)
- Limit the number of riders (if this happens, the ride leader will take people on a first come, first served basis, and then will create a waiting list and call people on the waiting list if someone else cancels)
- Depending on the nature of the trail and the experience level of the horse and rider, the ride leader may suggest that some riders not attend a specific ride.

All trail ride sign-ups are strictly on a first-come, first served basis.

Insurance Concerns

The LCHA Board of Directors discovered that our insurance company has been charging an additional fee for each event we sponsor in which non-members can participate. In Board discussions, we decided that we need to keep many of our events open to the public, but we also need to keep some events for members only to limit our insurance costs. Keeping the balance is important. Please notice that the calendar now marks some events **Open** and other events **LCHA Members Only**.

CLASSIFIED ADS

Clinics for Trail Riding: Small-group arena and trail sessions available, covering trail safety, etiquette, obstacles, and having fun with your horse out in the open. To receive clinic schedule updates or to request a session, contact instructor Kristin Schuett at kristin@freelyequine or go to www.freelyequine.com for more details.

For Sale Hand tied rope halters with lead rope. All sizes – from pony to draft. I can do halters for llamas also. Choose the color you want. A single halter and lead costs \$20. For multiple halters, call for pricing. Call Ted Newport Jr. (T.J.) 970-397-6986

For Sale Nice group of kind, gentle, and nice looking horses for sale, professional training, age 2 and up. See them on our web site @ www.Bridle-Bit.com

Also – Individual lessons, clinics, training from start to finish. Call 970-454-3061 or visit our web site at www.Bridle-Bit.com

Hoof Trimming Experienced & Certified Natural Hoof Care Practitioner. I will pull shoes and trim your horse for barefoot comfort. I carry a good inventory of hoof boots and I offer boots at the best prices around. Call Keith Jacobson, 970-391-1838 or visit my website www.naturalhoofcareofcolorado.com for more information.

Horsemanship/Symmetry, Balance, Moving with your Horse. Private lessons. Clinics on trail riding. Gaited horse. Cow working. Dressage. Ground work. Joe and Kim Andrews. 970-613-0121. www.mountainmagicranch.com

Leather Care Shop Leather repair and restoration. Saddle, tack cleaning and conditioning. Leather Artist; crafts, pictorial, and custom horse commissions. Joe and Kim Andrews 970-613-0121

Professional Vacation Care for your horses, dogs, cats and all other animals at your home. Quality, meticulous care is what CES provides so you will have peace of mind while you are away from home. Complete Equine Services also offers Lay-up care at your facility, Training Assistance, Riding/ Exercising horses, Beginning Riding Lessons, and Long/ Short-term feeding and cleaning contracts. Please visit CES at www.CompleteEquineServices.com for more detail on the services we provide or call Erin at 970-391-6457.

Ride Indoors at the Esh Training Center! Tired of the snow, wind and cold? Ride in our 100 x 200 indoor arena for a low haul-in fee of \$10. We also offer: colt starting, training, lessons and clinics. Visit our website at: www.paulesh.com or give us a call at 970-567-7505.

Stallion at Service: Cuttin Colonel, Sire: Colonel Freckles, Dam: Cutters Pretty. Foundation pedigree speaks for itself.

Outstanding disposition and athletic ability. NCHA Certificate of Ability, 1984 GNMCHA Maturity finalist, NRHA and AQHA performance point earners and money earning producer. Contact Mike Disque, TD Quarter Horses 303-229-3516, 970-532-9907, spirithorsemtn@msn.com

Editor's Note:

In the past, we have sometimes continued to publish classified information after an item is no longer useful; for example, an item for a trailer for sale ran two months after the trailer sold.

Policy: LCHA Roundup (this newsletter) will run "for sale" classified items for two months. If the owner of the item for sale wishes to extend the classified item, she/ he must contact the editor and request an extension. Without an extension, *LCHA Roundup* will remove the item from the Classified section. This policy does not affect classified information for services offered.

The Card Shop



287 Supply
New & Used Saddles
Tack & Accessories
For the Novice to the Professionals
Horseshoes & Complete Line of Shoeing Equipment

120 N. U.S. Hwy. 287
Ft. Collins, Colorado 80524
(970) 493-7322

Larry Cox Karen Cox

BETTS REALTY



2198 Devils Gulch Road
P.O. Box 550
Estes Park, CO 80517
(970) 586-0611
FAX (970) 586-0841
Toll Free 1-800-447-0305 Dianne@DianneBetts.com

Dianne Betts, GRI, CRS
Broker/Owner

Greener Pastures Transport
Animal Transportation
Deceased and Live Animal Hauling Solutions
- Local - Licensed - Free Estimates

Bonnie Stevens - Owner / Operator
(970) 224-1761 / (970) 690-4383

Lessons Training Clinics

UNITY WITH HORSES



Paul Esh
46715 CR 19
Nunn, CO 80648

(970) 567-7505
website: Paulesh.com

Mountain Magic Ranch
Horse Training Joe and Kim Andrews
Riding Lessons



101 So. C.R. 29
Loveland, CO 80537

(970) 613-0121
mountainmagicranch.com

**SPOTTED
FEVER
RANCH**

Rick & Pat Binger
9057 ECR 26
Loveland, CO 80538

**Registered
Paint
Horses**

www.spottedfeverranch.com
rick@spottedfeverranch.com
970-222-3656

Century 21

Kristine Rampone
Broker Associate

Humpal, Inc.

210 East 29th Street
Loveland, Colorado 80538
Office (970) 663-2400
Cellular (970) 443-4913
Fax (970) 663-6911
KristineRampone@century21.com



Each Office is Independently Owned And Operated

NATURAL HOOF CARE
OF COLORADO

KEITH JACOBSON
CERTIFIED NHC PRACTITIONER
970-391-1838

BAREFOOT TRIMS FOR COMFORT AND PERFORMANCE
WWW.NATURALHOOF CAREOF COLORADO.COM



Freely Equine, LLC

Kristin Schuett
Western & Hunt Seat Instruction
Horse Training
Trail Lessons



CHA

Improving teamwork between you and your horse.
970-443-2758 E-mail: kristin@freelyequine.com
Serving Northern CO Web: www.freelyequine.com

Larimer County Horseman's Association

ALL-AMERICAN
Horse Feed

TRIPLE CROWN
NUTRITION, INC.

10%
Discount Card
Redeemable at:
Ranch-Way Feeds Retail Store
546 Willow, Fort Collins, CO
970-482-1662
www.Ranch-Way.com

RANCHWAY FEEDS

Please present your current LCHA membership card at time of purchase

Rocky Mountain RIDER
Regional All-Breed Horse Magazine — Since 1993

Natalie Riehl
Publisher/Editor

PO Box 995 • Hamilton, MT 59840
406-363-4085 • 888-747-1000
Fax 406-363-1056
editor@rockymountainrider.com
www.rockymountainrider.com

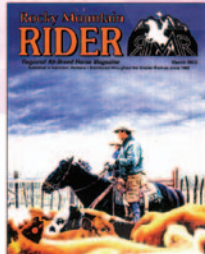

Front Range Exceptional Equestrians
Therapeutic Riding Program

Providing a unique blend of social, physical, and emotional development through therapeutic horseback riding

PO Box 272452
Fort Collins, CO 80526

Voice Mail (970) 221-0646
www.ridewithfree.org

A NARHA Premier Accredited Center



Sundance Trail Guest Ranch

Fall, Winter and Spring - Country Inn with Meals and Horse-Back Riding
- Family Get-Aways and Small Business Retreats
- Ride Our Horses or Bring Your Own!
Summer - Family Dude Ranch Vacations (Six Night Minimum)

Ellen & Dan Morin
17931 Red Feather Lakes Rd.
Red Feather Lakes, CO 80545



(970) 224-1222 or (800) 357-4930
www.SundanceTrail.com
Horses@SundanceTrail.com

SUN PONY RANCH

A relaxed atmosphere with premier facilities in which to board your horse and / or learn to ride.

18430 WCR1
Berthoud, CO 80513
Phone: 970-532-4040
www.SunPonyRanch.com



Mannatech
Hope. Health. Opportunity.

KAY D. THOMSON, M.A.
Independent Associate
Regional Director

2563 County Rd. 42
Berthoud, CO 80513
Cell: (970) 443-7111
Fax: (970) 532-2443
kay@lpbroadband.net
www.mannapages.com/kaythomson



The Card Shop

Ride the Western Trails Publications presents

Introducing
Horse Trails of "Colorful" Colorado

BOOK 1 - Larimer, Weld, Yuma Counties (B&W)
 BOOK 2 - Adams, Boulder, Douglas, Jefferson Counties
 BOOK 3 - Larimer, Boulder Counties

• Mountain & Flatland Trails
 • Full COLOR Pictures
 • Trail Descriptions, Length and Usage, Directions, Elevations, Maps, Difficulty Rating... and much, much more!

Visit us at www.horsebacktrails.com or Call (970) 222-4943

Complete Equine Services
Peace of Mind for You AND Your Horses!

970-391-6457

Erin Wilson-Kaufman, Owner
 1931 ECR 58
 Fort Collins, CO 80524
www.CompleteEquineServices.com
erin@completeequineservices.com

MOUNTAIN VET SUPPLY

Toll Free 1-800-331-5544

149 John Deere Dr.
 Ft. Collins, CO 80524
 970-484-2200

Represent YOUR business in the Larimer County Horseman's Association Newsletter

Advertising rates per issue (\$):

Membership Type	Classified	1/8	1/4	1/2	Full
Business	Free*	Free*	5.00	10.00	20.00
Individual or Org.	Free**	5.00	5.00	10.00	25.00
Non-Member	\$3.00	7.50	10.00	12.50	25.00

* Only one free ad per issue ** On space-available basis

For more information, contact Hugh at 970-622-0982 or htempt@mcleodusa.net

10% Discount on regular prices with LCHA Member Card

Complete lines of Tack, Supplements, Vaccines, & Medications

VETLINE EQUINE INC.
Animal Health • Nutrition

(970) 484-1900
 (800) 962-4554

8 - 5:30 M-F
 9 - 1 Saturday

425 John Deere Rd., I-25 & Hwy 14 behind Holiday Inn, Ft. Collins
www.vetlineequine.com

Precious Memories

Pet Cemetery and Crematory

5815 E. Hwy 14
 Fort Collins, CO 80524
 (970) 482-7557

Bridle Bit

Training and Tack, LLC

Steve & Amy LeSatz

Training
 Lessons
 Clinics
 Breeding
 Horse Sales
 Tack Sales

19442 WCR 76 • Estes, CO 80525
 phone and fax: (970) 454-3061
 e-mail: bridlebitllc@msn.com
 website: www.bridle-bit.com

Bonnie Robinson - Broker/Associate

RESIDENT REALTY

8010 Co Rd 5, Suite 102
 Fort Collins, Colorado 80528
 Phone: (970) 223-3361 Cell: (970) 215-1142
 Fax: (970) 377-4109
 Email: Bonnie.Robinson@msn.com
www.bonnie-robinsonhome.com
 Owned & Operated by: The Plantz Family Network, Inc.

EQUINE MEDICAL SERVICES
 3021 West County Road 64 - Fort Collins, CO 80524

Excellence in Performance Horse Care
 Including field & in-clinic reproductive services & surgery

For Appointments and Information
(970) 568-9445
Fax (970) 568-0705
www.emsvet.com

Dr. Allen Landes

WALKING OUT WEST

Gaited Horse Training
 Lessons
 Clinics

Debbie Garfield, Trainer
 (303) 725-3551 Cell
 Email: walkingoutwest@yahoo.com

My Source, LLC
 First Class RV, Trailer Renovation

Paul Thomson
 Master Carpenter
 Master Cabinet Maker
 Over 30 years experience
 2563 CR 42
 Berthoud, Colorado
 970-581-8977
 Floors, walls, cabinets, custom built-ins... I do it right!
 Call now for an estimate.

(This area is currently blank in the provided image)

37 Years of Service

LCHA Roundup



Larimer County Horseman's Association

P.O. Box 270375

Fort Collins, Colorado 80527-0375