

**ESR tot. < 0.15 Ohm**  
**Irms tot. > 2.5A**

**230uF < Cap. tot. < 460uF**  
**4mOhm < ESR tot. < 22mOhm**  
**Irms tot. > 2.5A**

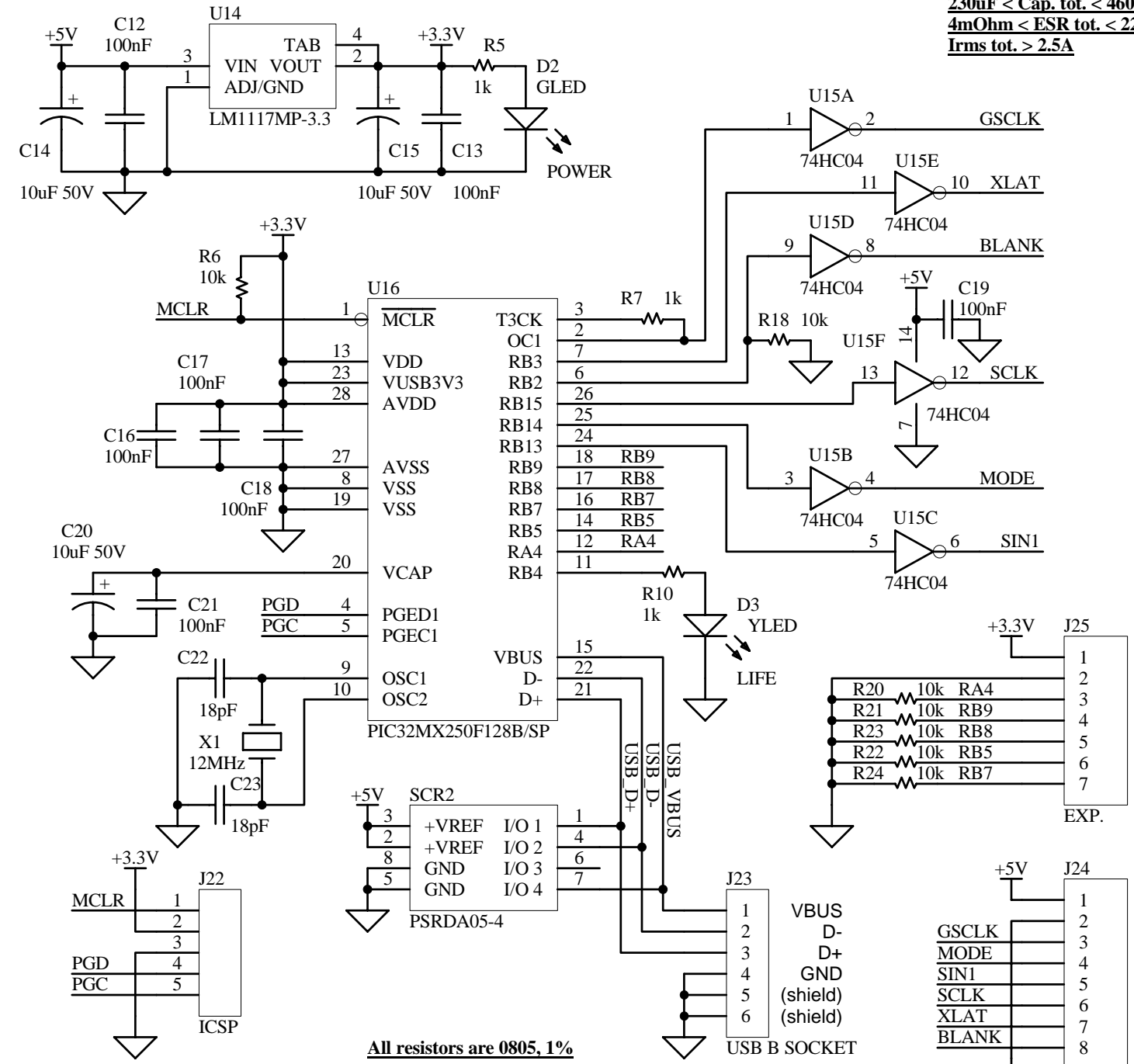

**All resistors are 0805, 1%**

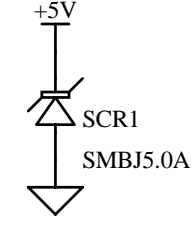
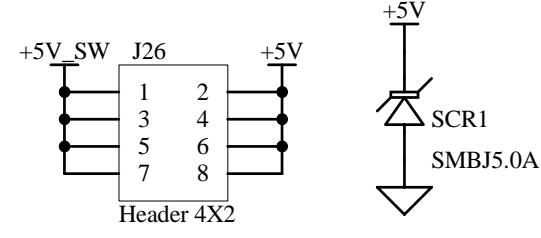
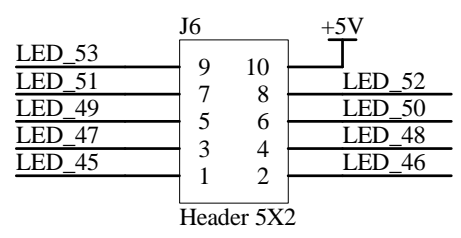
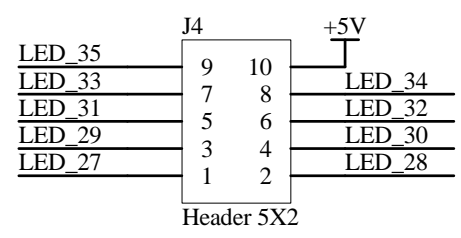
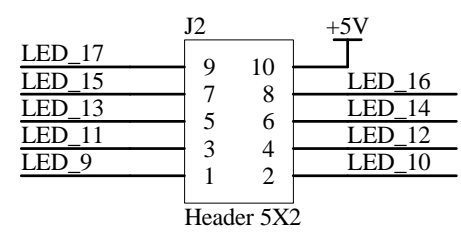
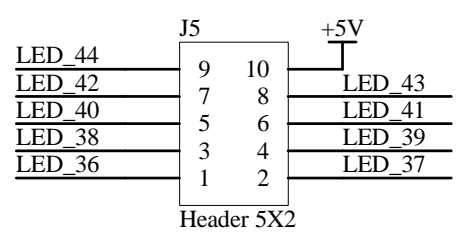
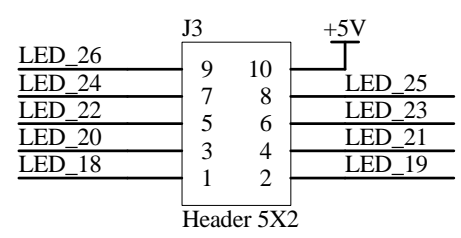
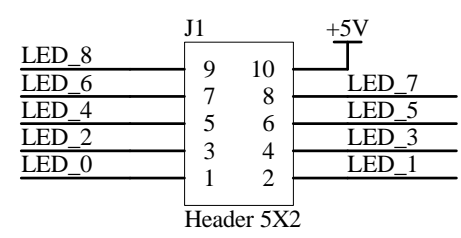
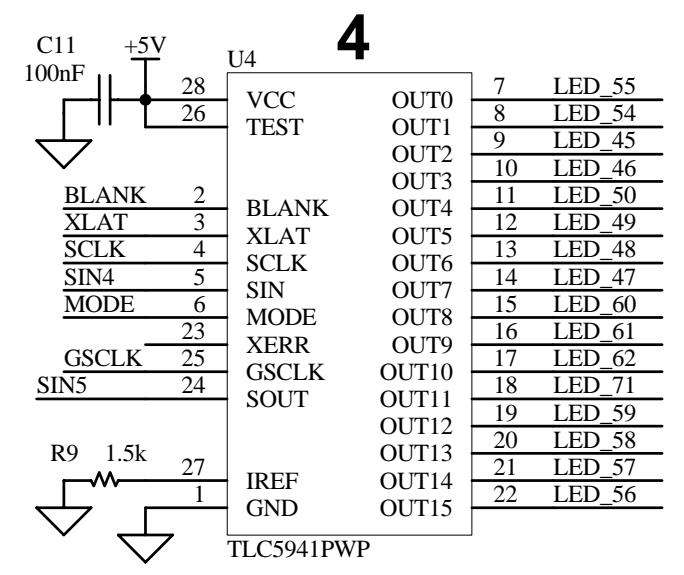
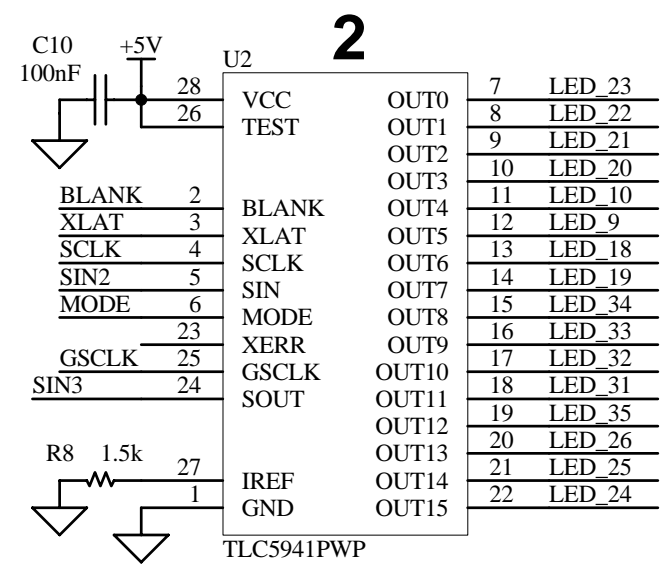
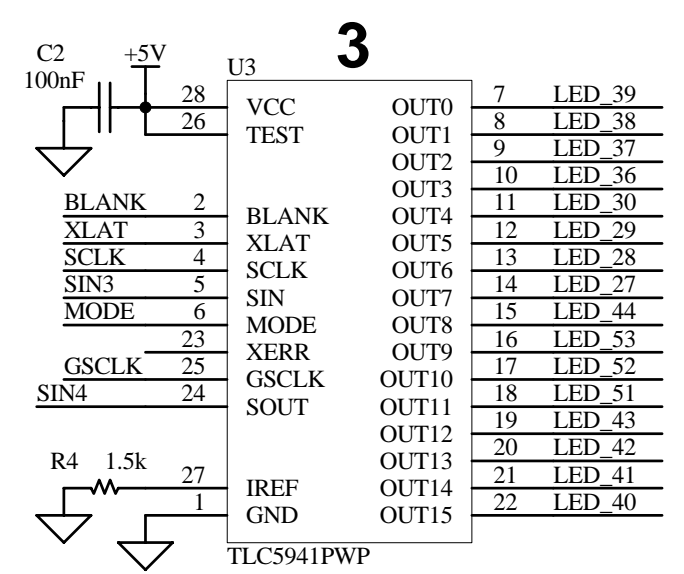
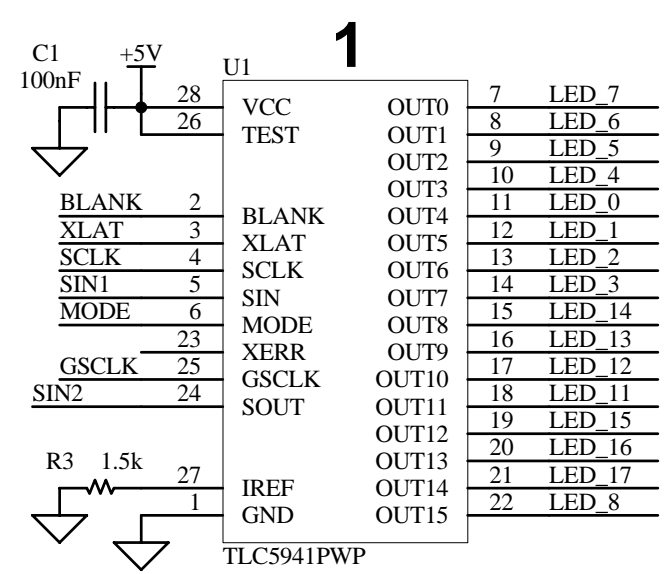

| Title                        |   |              |
|------------------------------|---|--------------|
| <b>STAR Led Driver Board</b> |   |              |
| Size                         | Number  | Revision     |
| A4                           |   |              |
| Date:                        | 05/10/2015  | Sheet 1 of 2 |
| File:                        | C:\Programmi\...\Star 2015 - sheet1.SchDoc Drawn By: E.B. |              |

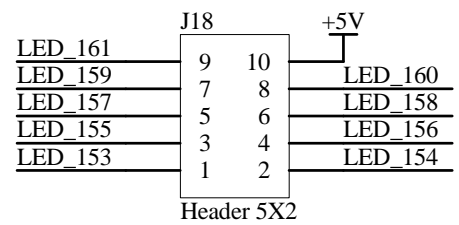
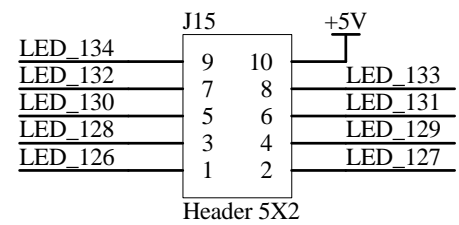
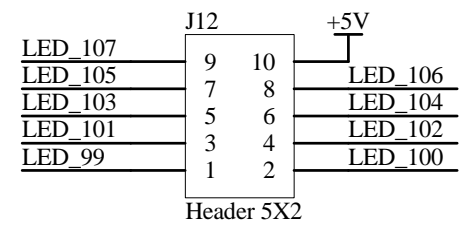
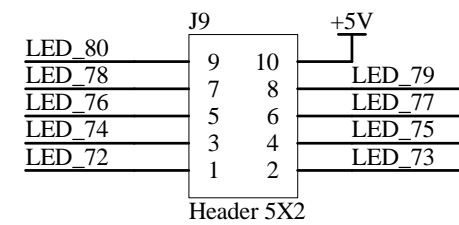
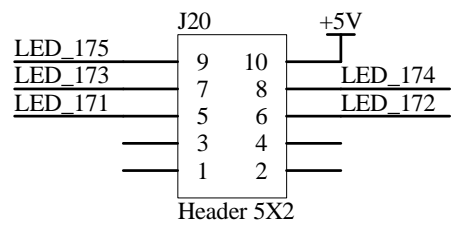
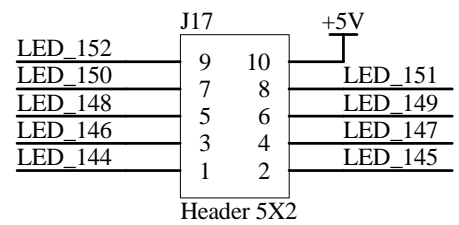
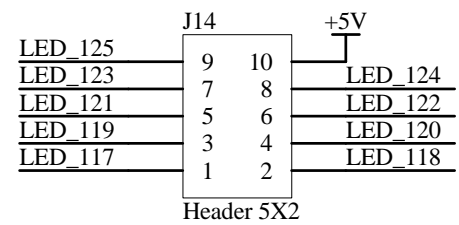
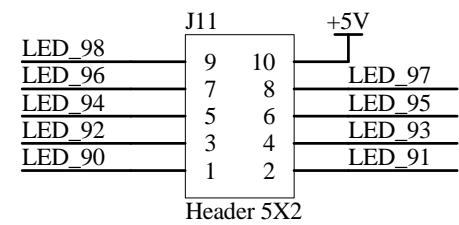
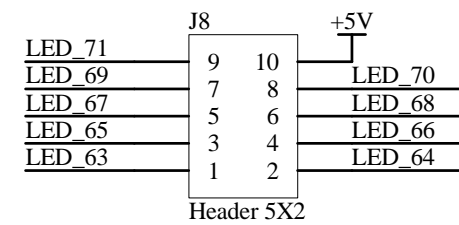
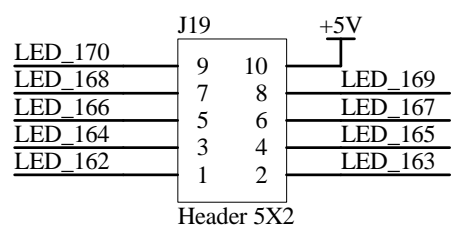
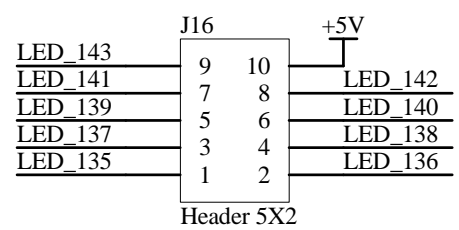
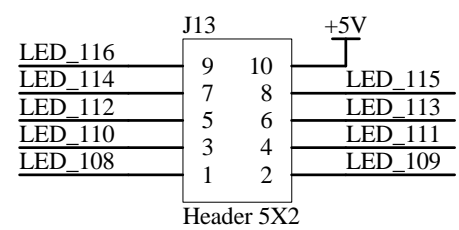
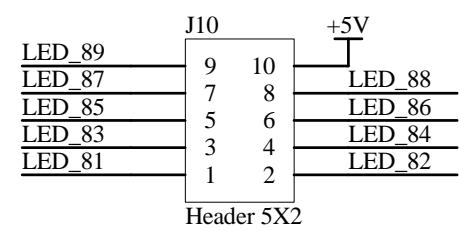
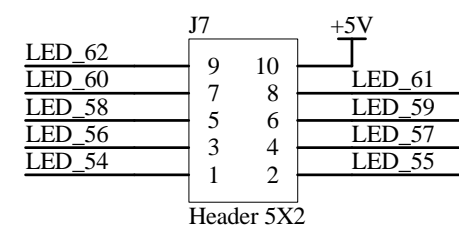
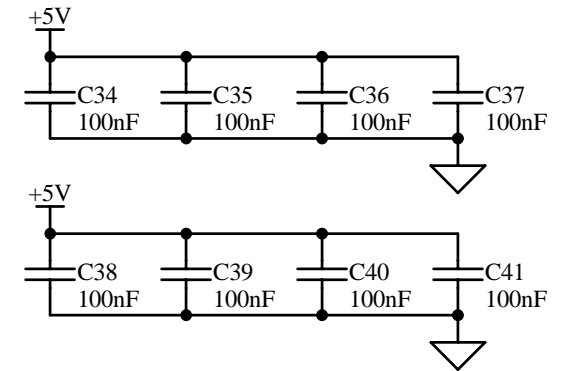
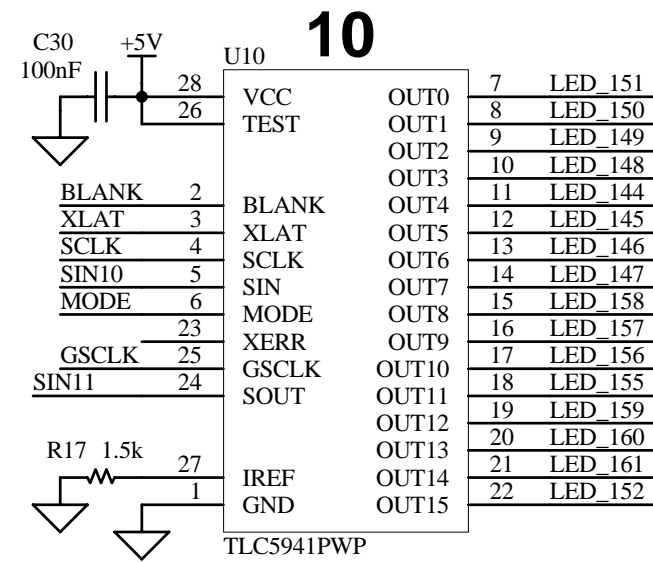
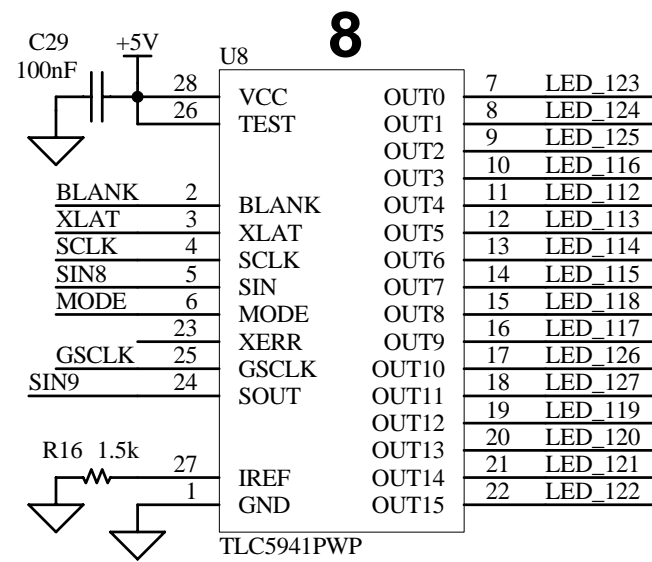
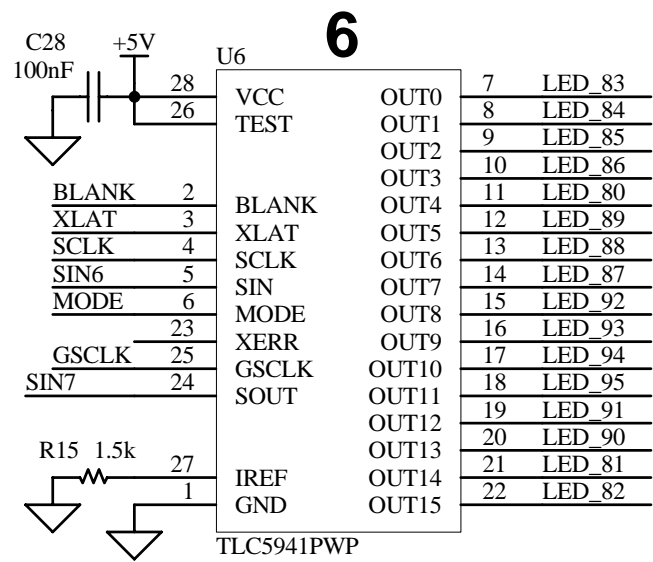
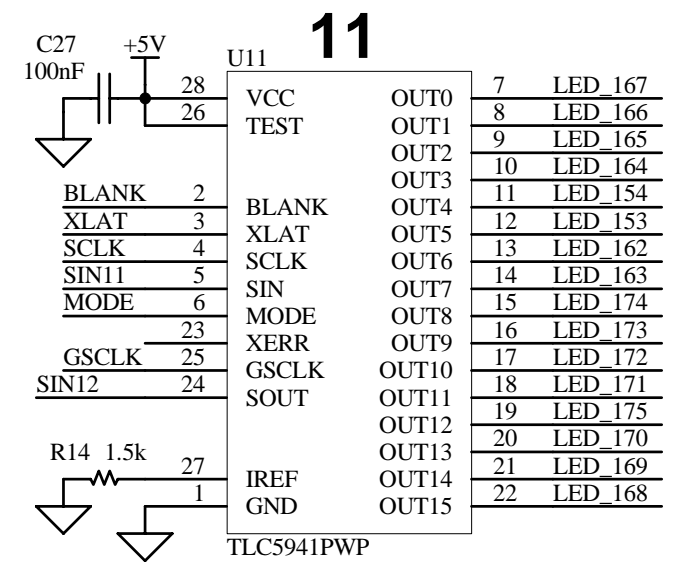
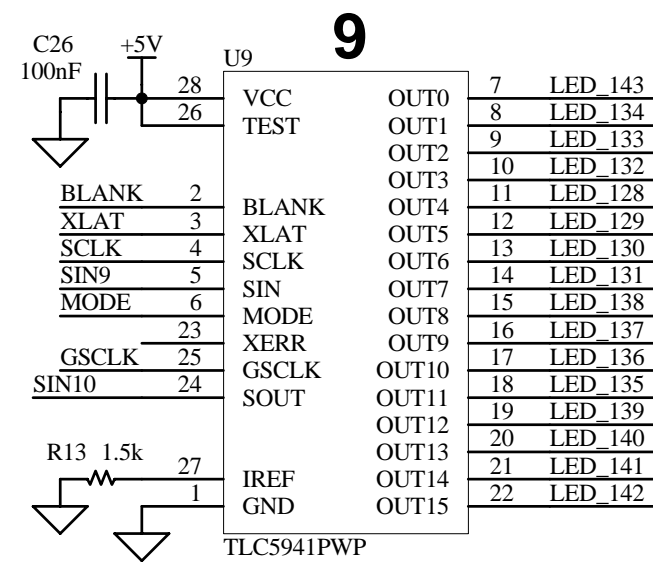
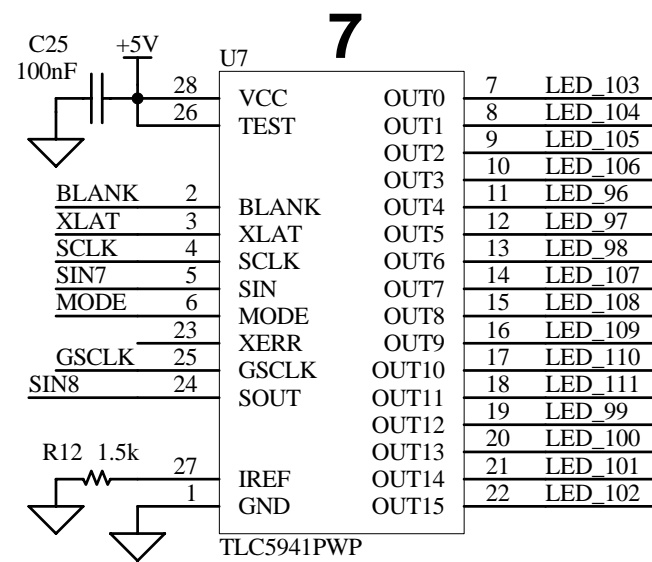
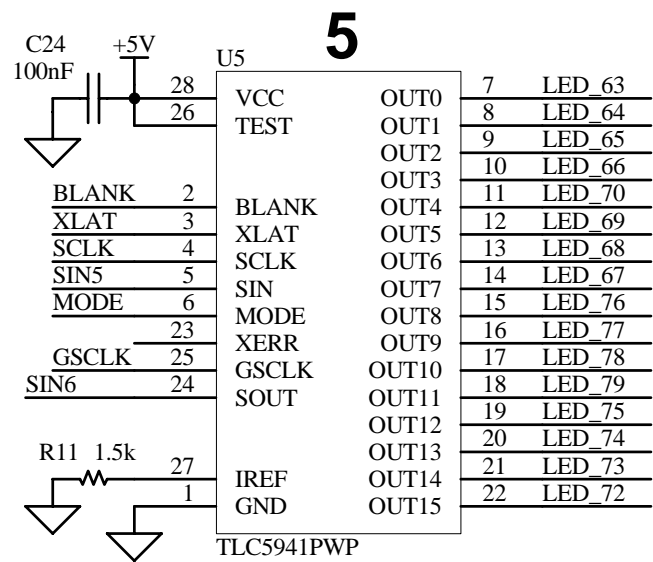

|                              |   |              |
|------------------------------|---|--------------|
| Title                        |   |              |
| <b>STAR Led Driver Board</b> |   |              |
| Size                         | Number  | Revision     |
| A4                           |   |              |
| Date:                        | 05/10/2015  | Sheet 2 of 2 |
| File:                        | C:\Programmi\...\Star 2015 - sheet2.SchDoc Drawn By: E.B. |              |

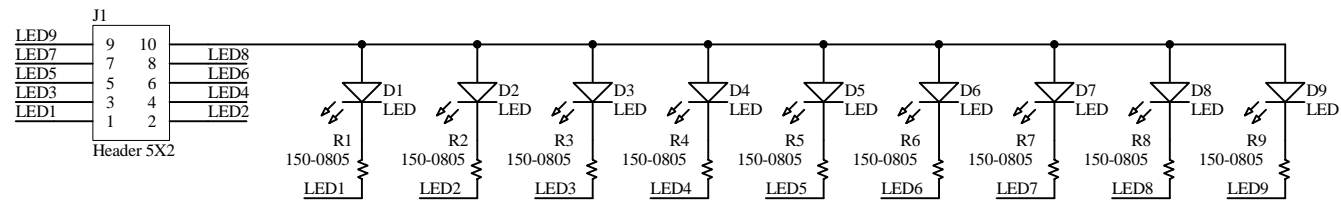

|                |                                 |                |
|----------------|---------------------------------|----------------|
| Title          |                                 |                |
| <b>Led Bar</b> |                                 |                |
| Size           | Number                          | Revision       |
| A4             |                                 |                |
| Date:          | 05/10/2015                      | Sheet 1 of 1   |
| File:          | C:\Programmi\...\Led Bar.SchDoc | Drawn By: E.B. |