

()

()

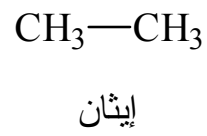

. () .

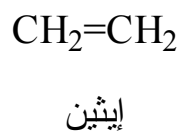
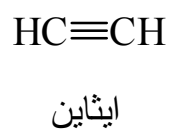
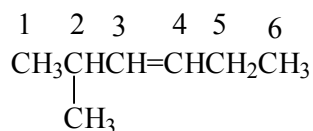
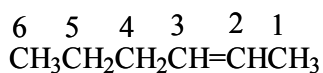
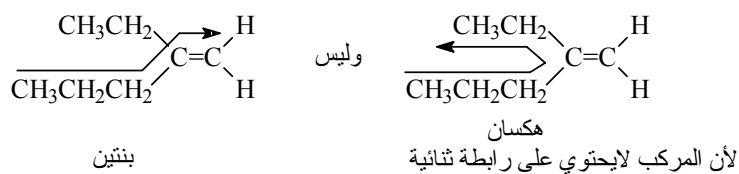

[.]

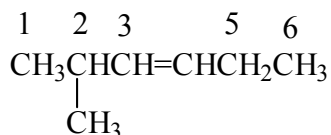
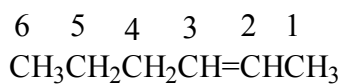

2 - هكسين

2 - ميثيل - 3 - هكسين

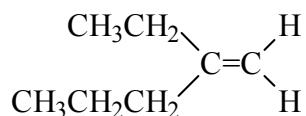

2 - إيثايل - 1 - بنتين

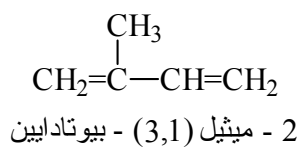

2 - ميثيل (3,1) - بيوتاديين

. ()



2 - بنتاين

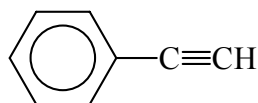

فينايل إيثاين

C1,C2

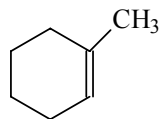

1- میتیل -1- سیکلو هکسین



سایکلو هکساداین (4,1)

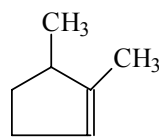

ثنائی میتیل سایکلو پنتین (5,1)

(-)



2- اوکتین -6- آین

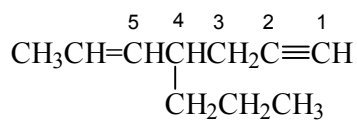

4 پروپیل -5- هپتین -1- آین

(IUPAC)

:

$\text{CH}_2=\text{CH}_2$		
$\text{CH}_3\text{CH}=\text{CH}_2$		
$(\text{CH}_3)_2\text{C}=\text{CH}_2$	-	
$\text{CH}_2=\text{C}(\text{CH}_3)\text{CH}=\text{CH}_2$	- , - -	
$\text{HC}\equiv\text{CH}$		

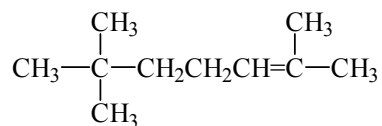

:

: - -

: - -

- a) $\text{CH}_2=\text{CHCH}_2\overset{\text{CH}_3}{\text{CH}}\text{CH}_3$
 b) $\text{CH}_3\text{CH}_2\text{CH}=\text{CHCH}_2\text{CH}_2\text{CH}_3$
 c) $\text{CH}_2=\text{CHCH}_2\text{CH}=\text{CHCH}_3$
 d) $\text{CH}_3\text{CH}_2\text{CH}=\text{CHCH}(\text{CH}_3)_2$

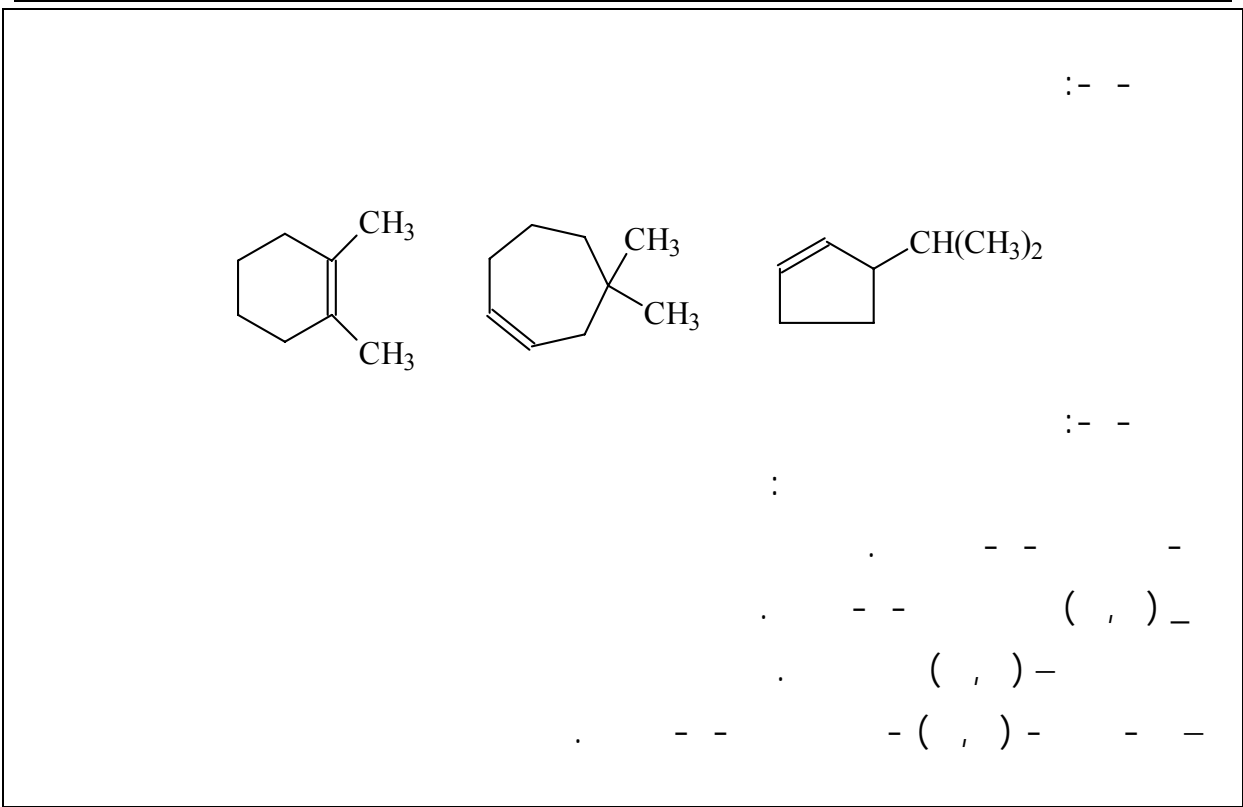

. - - - -

(C=C)

(H-C-H C-C-H) (sp²)

° =

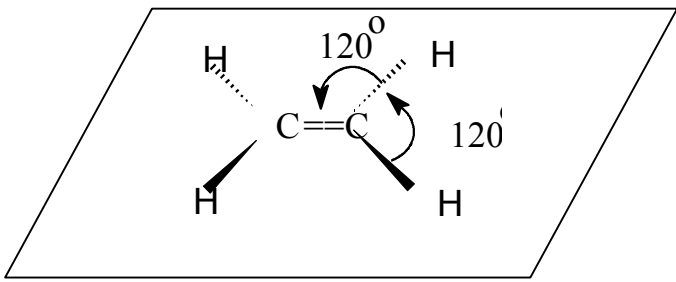

(σ) (sp²)

(p) (sp²)

(π)

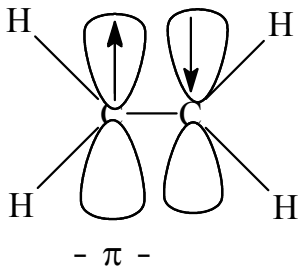

() (- -) () (- -)



هذان المتشاكلان متطابقان
حيث لا يوجد متشاكل تجاور وتضاد

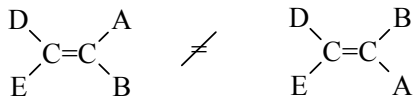

هذان المركبان غير متطابقين
اذن هذان متشاكلان

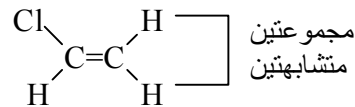
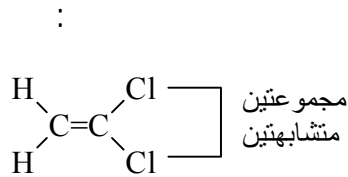
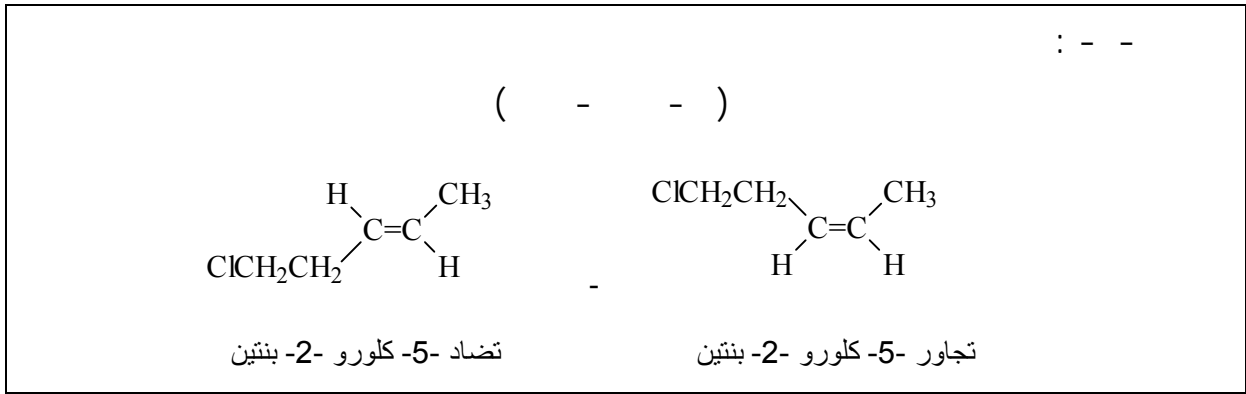

(+)

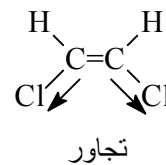
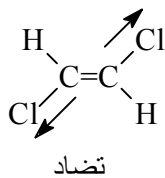

(E,Z) - -

(E,Z)

(+)

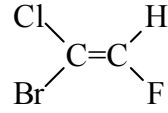
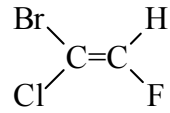

:

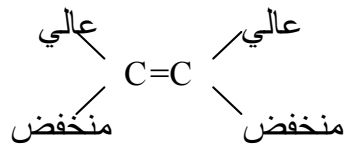

(Z)

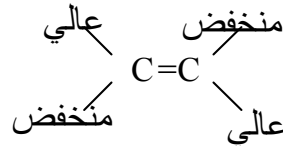

(E)

: (E,Z)

Z ()

E ()

: _____

: _____

(Br > Cl > F > O > N > C > H)

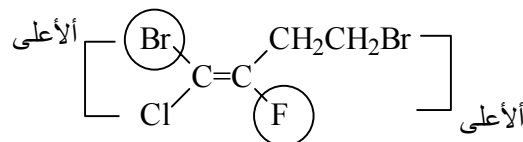

(E)

isopropyl > CH_3CH_2 > CH_3

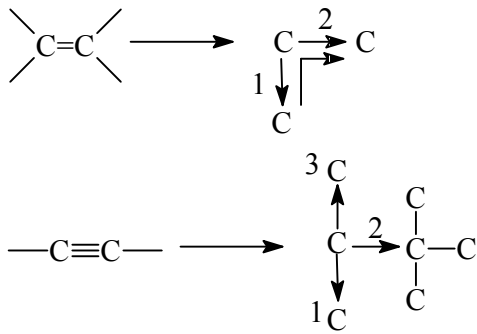

(E,Z)

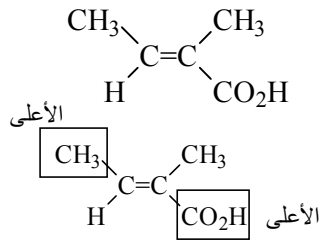

(E)

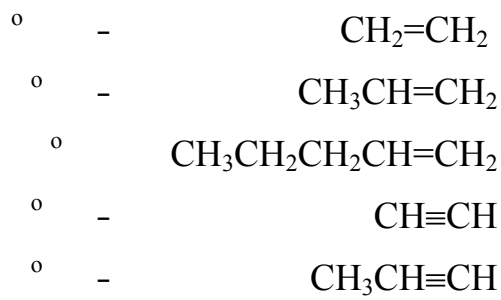

_____ - -

(-) π

_____ - - -

() Al_2O_3 H_3PO_4 H_2SO_4

C- OH

C-O⁺H₂

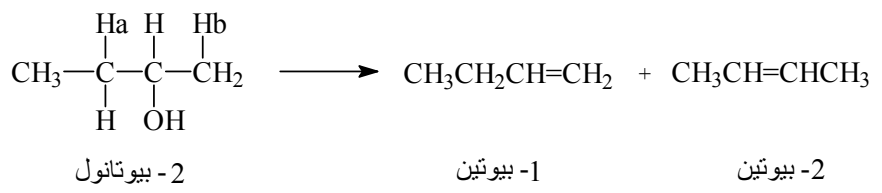

Ha

-

-

-

Hb

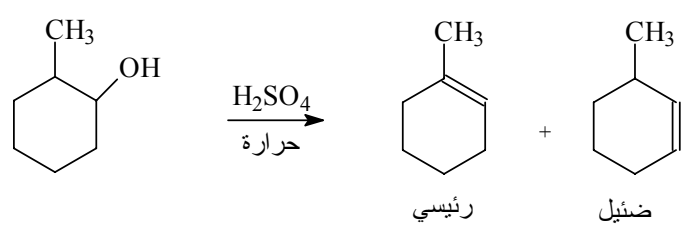
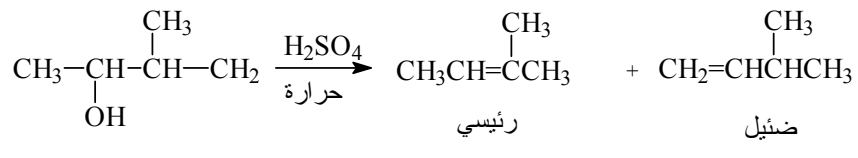

HX

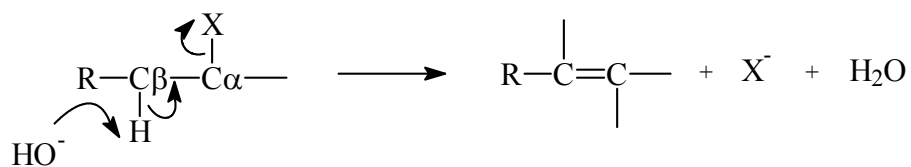

:

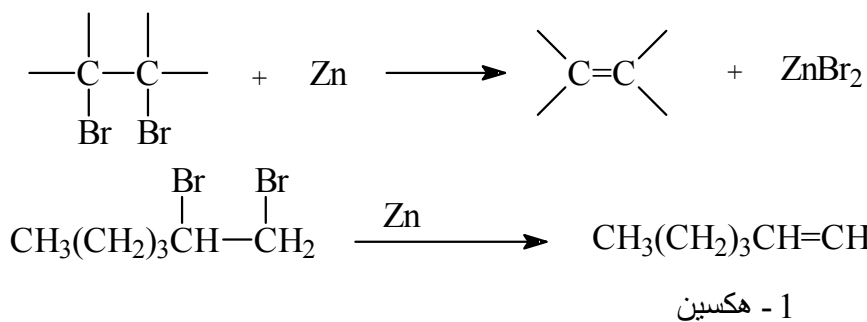
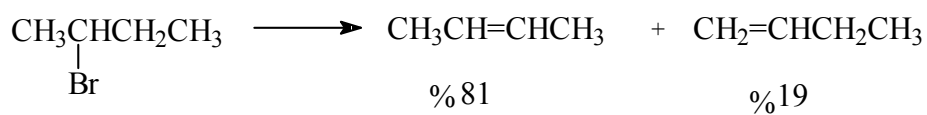
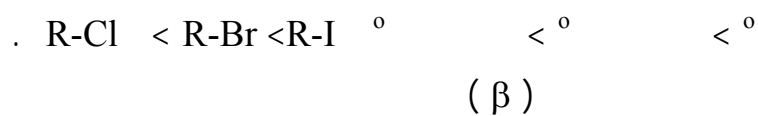

400

()

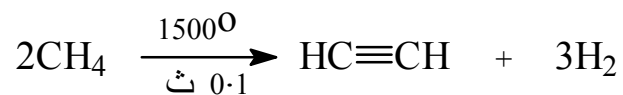
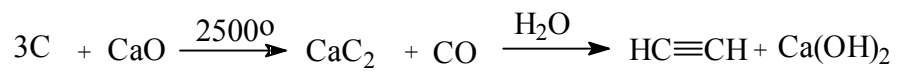
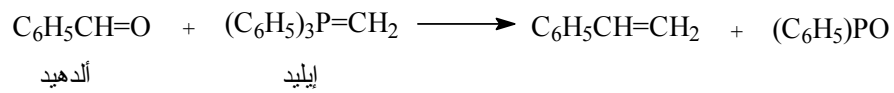
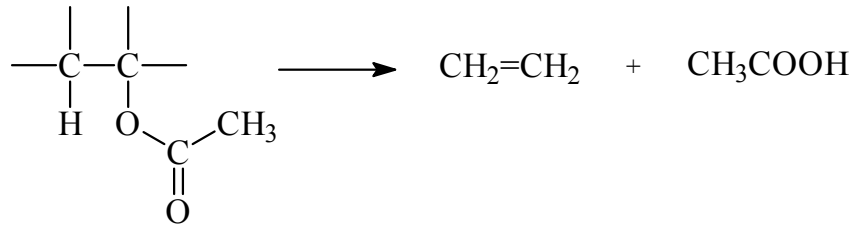

(. .)

300

)

(

. NH₂

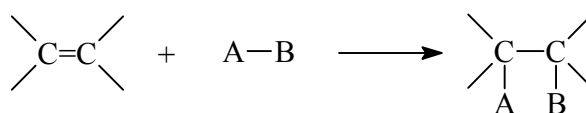
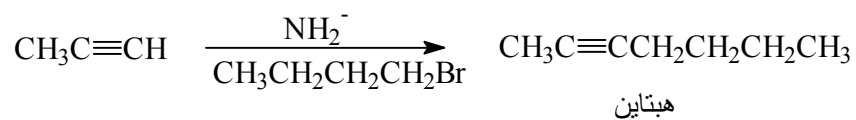
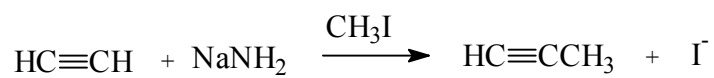

.Pd

. () H₂

Ni

Pt

H-H

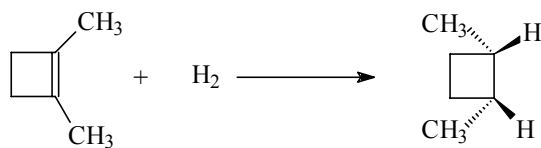
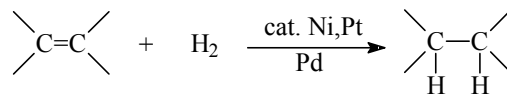

() - - -

: CCl₄

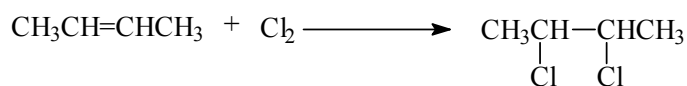
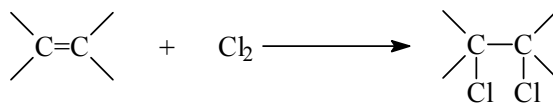

(3,2) ثنائي كلورو بيوتان

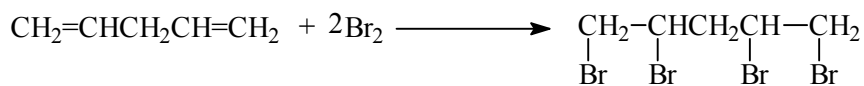

(5,4,2,1) رباعي بروموبنتان

CCl₄

(,)

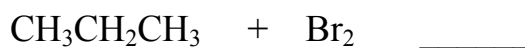

: - - -

(HI, HBr, HCl, HF)

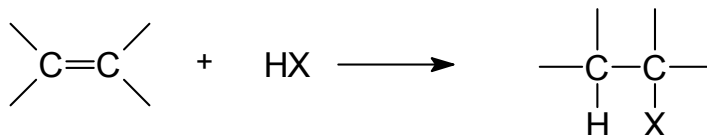

:

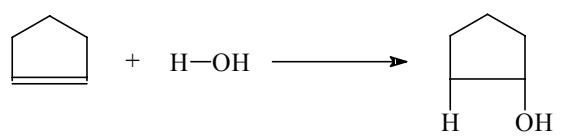
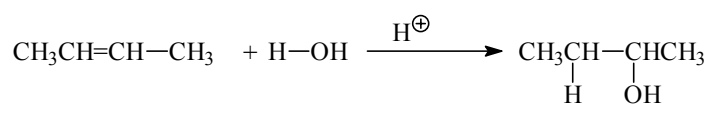
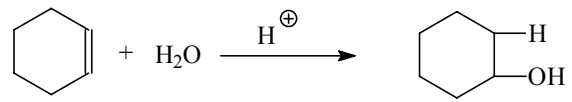
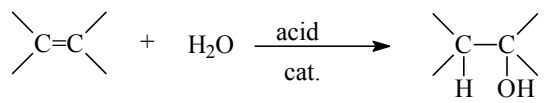

: _____ - - -

[R-COOH]

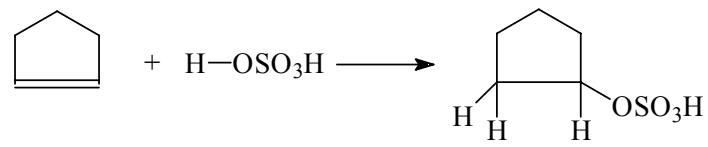
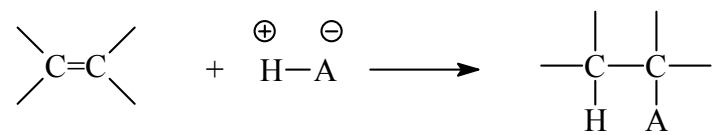
(HX, H₂SO₄) :

: _____ - - -

() :

(/)

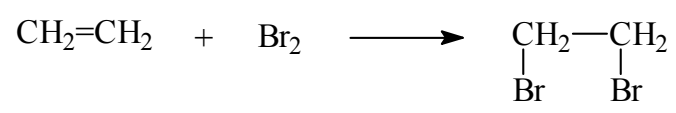

. ()

(+)

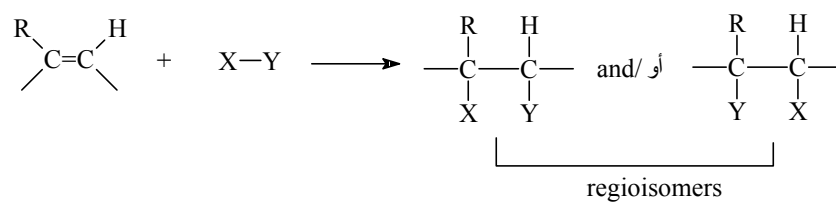

:

:

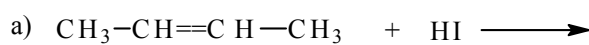

: - -

: - -

:

