



MagPro™ Bill Acceptor

Installation & Operation Guide

INTRODUCTION

This page contains general information on installing, operating and maintaining the MagPro Bill Acceptor. Taking time to read this information will help you obtain the best performance from your MagPro.

The MagPro is the result of extensive research and development in computerized crediting systems. This greatly simplified unit provides many important features never before available in any bill acceptor. The MagPro extends the capability of the vending machine. Some of the unit's many outstanding features include:

- Snap-in modules for easy cleaning and on-the-spot service
- Illuminated Inlet
- Impact resistant mask
- Anti-Jam Software
- Accepts all or any combination of the following bills: \$1, \$2, old and new \$5, old and new \$10 and old and new \$20
- Option switches customize the unit to fit the specific needs of the location
- Dollar bill escrow feature
- Standard and Multi-Drop Bus (MDB) interface
- Most components are made of industrial grade resins, making it resistant to salting, corrosion and rust

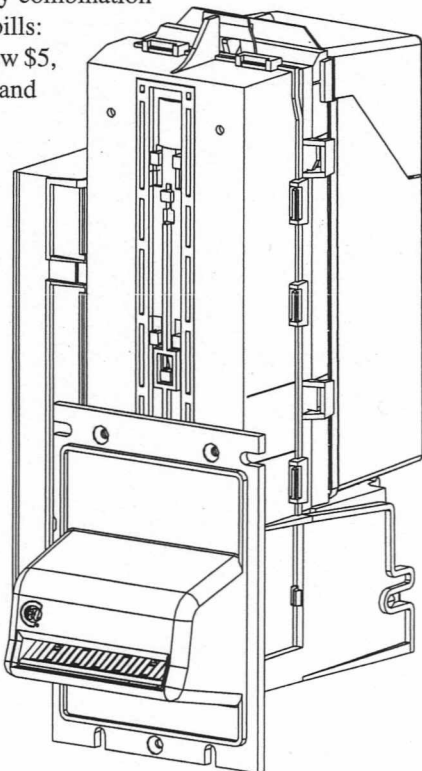

INSTALLATION AND OPERATION

Before installing the MagPro into the vendor, set the option switches as desired (see "Setting Option Switches" section for detailed information).

1. Turn OFF vending machine power.
2. Connect the MagPro interface harness (not included) between the MagPro and the vending machine.
3. Install the MagPro into the mounting hole of the vending machine using the appropriate hardware (not included).

NOTE: Should additional mounting hardware or harnessing be required, please contact your local Coinco office.

4. Restore power to the vending machine. The MagPro stacker will cycle upon power-up.
5. Observe that the power indicator light on back of MagPro control box is ON continuously. If the light is OFF or blinking, check the following:
 - Power to vendor.
 - Vendor is not disabling the bill acceptor.
 - Bill acceptor interface harness.
 - Vendor does not have credit already established.
6. With the vend price set below one dollar, insert a one dollar bill as shown on the front of the unit.
7. The bill will be accepted and stacked in the bill box.
8. Verify one dollar credit has been established.
9. Check the bill box to see that the one dollar bill is properly stored.

ABOUT THE OPTION SWITCHES

On the MagPro control board, there is an option switch module containing eight switches. These switches allow the unit to be customized. These option switches are factory set and shipped with switches 3 and 8 set to the ON position. This setting allows the highest acceptance of one dollar bills only, face up in both directions.

SETTING THE OPTION SWITCHES

See Figure 1. Remove power to the unit. Remove the bill box to access the option switch access hole on inner side panel of logic board case. Using a small screwdriver, set option switches through access hole.

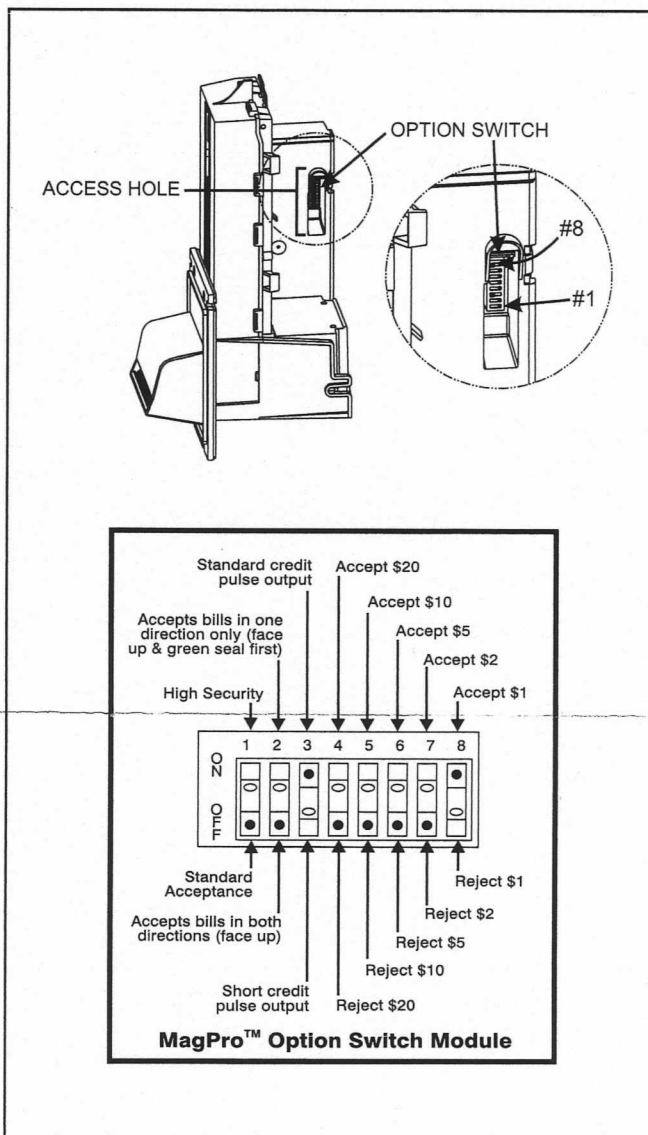

Figure 1

REMOVING ACCEPTED BILLS

See Figure 2. Accepted bills may be removed by releasing the bill box lid exposing the bills for collection or by removing the bill box from the bill acceptor unit.

CLEARING JAMS AND CLEANING

See Figure 2. Trapped bills/debris or dirt can result in poor bill acceptance or bill rejection. Remove bill box and lower housing to access bill path for clearing trapped bills or debris. Clean bill path plastic parts with a cloth moistened with a mild soap and water solution. Clean the magnetic head and optic sensors using a swab and isopropyl alcohol. **Do not use any petroleum based cleaning solvents, scouring pads or stiff brushes for cleaning. The MagPro requires no lubrication at any time.**

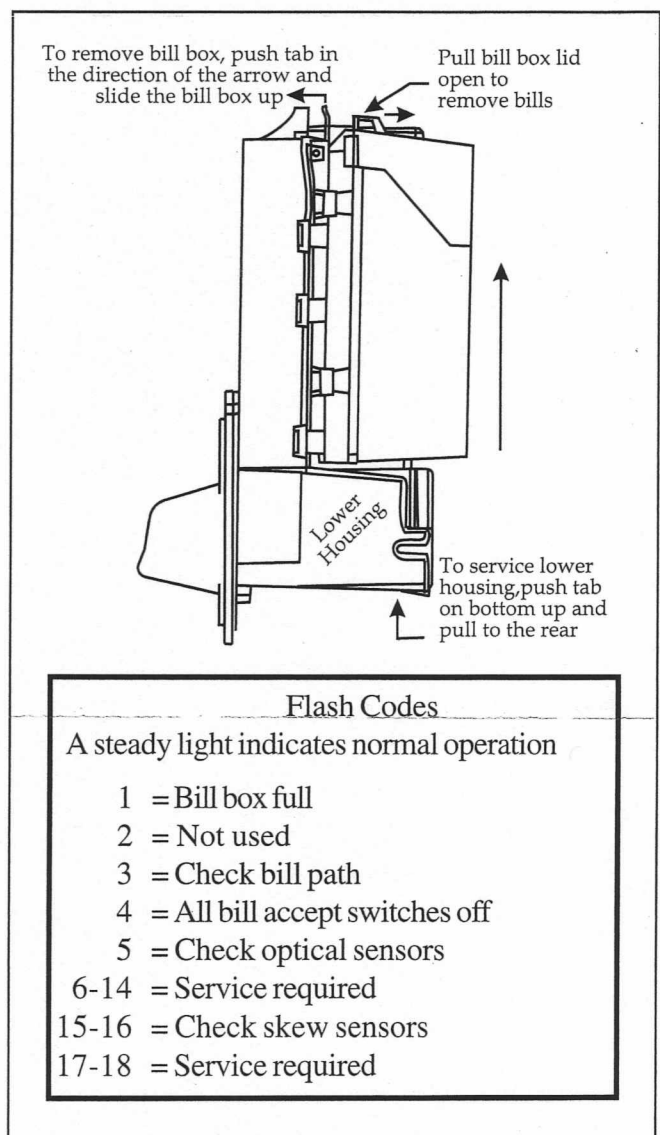

Figure 2