

***Fox Tango International  
Presents The Yaesu FT-200,  
Sommerkamp FT-250, Henry Tempo One***



**For more information about the FT-200, Tempo One check out the club CD**

# "ZL" FT-200 Newsletters, FT-250, Tempo One CD ROM



**FT-200 And FT-200S Low Power version sold in Japan, AKA FT-250 European Version.  
Same rig sold in the United States by Henry Radio of Los Angeles as the Tempo One**



*Even as old as she may be, she's still a pretty face!*



*Tempo VF/1 VFO, Tempo One Xcvr, Tempo AC/One  
Tempo One Restoration Project ~W4CLM~*



**How about taking your Tempo One Mobile?  
An inside peek of the DC/1A DC-DC Power convertor.**

***Sold in the United States by Henry Radio of Los Angeles California as the Tempo One, it sold in both white & black version.***



**Henry Radio also sold a remote VFO the VF/One for this transceiver can be difficult to find.**

**Finding one can prove to be a challenge, this VF/One luckily showed up on Ebay, but I had to buy the whole rig to get it. With a little soap and water it cleaned up**

**as good as new**



<b>Frequency range:</b>	10-80 m
<b>Mode:</b>	AM/SSB/CW
<b>RF Power output:</b>	100 W
<b>Voltage:</b>	Mains or 12 VDC with Option DC-200 Supply
<b>Current drain:</b>	RX: 12.5 A @ 12 VDC



<b>Current drain:</b>	TX: 15-27 A @ 12 VDC
<b>Impedance:</b>	50-100 ohms, SO-239
<b>Dimensions (W*H*D):</b>	13.25 x 5.5 x 11"
<b>Weight:</b>	8 Kg
<b>Manufactured:</b>	19xx-19xx
<b>Other:</b>	
<b>Extras:</b>	FV-200 matching VFO

**Accessories for the FT-200 / FT-250 Included the Yaesu DC-200 Mobile 12 volt DC power supply  
And the Yaesu FV-200 remote VFO**



## FV-200 EXTERNAL VFO



FV-200 External VFO is designed to provide versatile operation of the FT-200 transceiver.

## DC-200 DC POWER SUPPLY

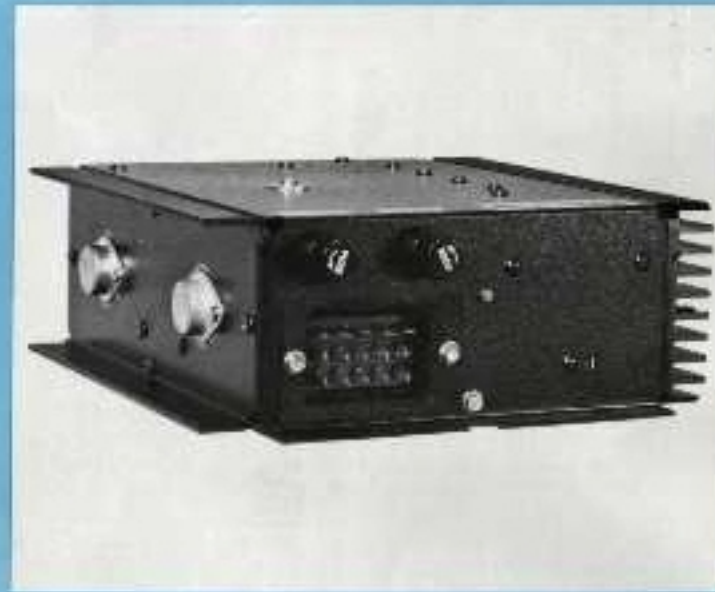

The DC-200 DC mobile supply is designed for the FT-200 Transceiver. This supply provides all necessary voltages from 12 volt battery for mobile operation.



*An Ebay Special VF/One cleaned up nicely*

**[Download Owners operators manual for \(VFO\) FV200 / Tempo FV/One](#)**

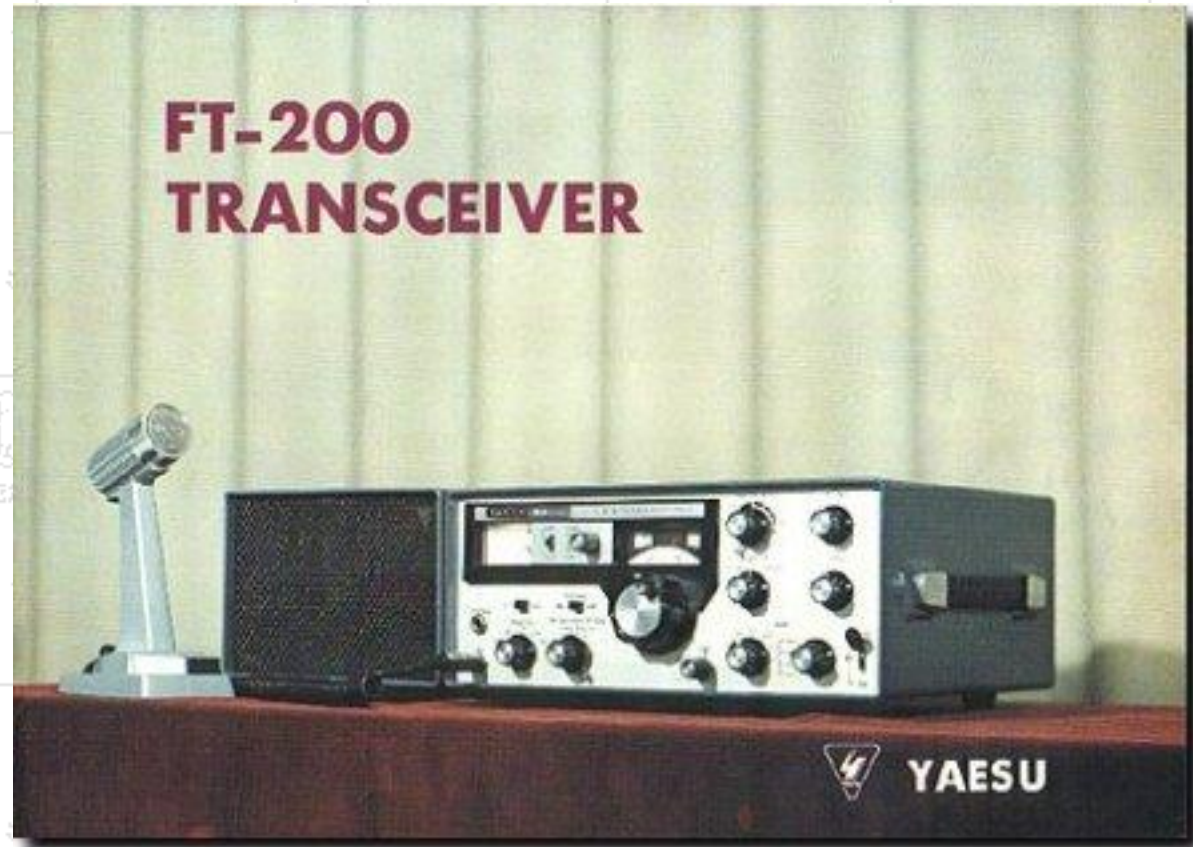

**The (100 watt) FT-200 sold in Japan for Y69,000 Yen.  
FT-200 was also sold in Australia and Europe.**



**The FT-200S (10 watt version)  
was sold in Japan with a single tube in the final amplifier stage.  
Options included a 100w upgrade kit for Y3000 Yen.  
And 100 KHz Crystal Calibrator for Y1500 Yen.**



CONCENTRIC SHAFT CONTROL FOR PA PLATE AND LOADING CONDENSERS



# Concentric Shaft Control for PA Plate and Loading Condensers



## VFO Gear Mechanism



**SOMMERKAMP FT 250**  
Der preiswerte Taschenempfänger mit Full-Track-Unter dem Schirmblech für Messwerk zur Störprüfung ist der Standardempfänger für alle Mittel- und Kurzwellenverläufe für die Amateurstationen 30-30 MHz. Geeignet für Zehntelwellenlängen unter der Frequenzgrenze bis 30 MHz.  
Prüfungsschaltung:  
L1: 4,5 MHz 50 µH L2: 7,1 MHz 10 µH L3: 17,5 MHz 50 µH  
L4: 21,5 MHz 15 µH L5: 20,5 MHz 10 µH L6: 20 MHz 10 µH  
Antenneneingangsnetz: 500 Ohm Netz 100 Ohm Netz 200 Ohm Netz  
Netzspannung: 100-250 Volt Netz 100 Volt Netz 200 Volt Netz  
Leistungsvermögen: 100 Watt bei 500 Ohm 100 Watt bei 200 Ohm  
Die Schaltung ist einstellbar für alle Mittel- und Kurzwellenverläufe. Geeignet für Zehntelwellenlängen unter der Frequenzgrenze bis 30 MHz. Geeignet für Zehntelwellenlängen unter der Frequenzgrenze bis 30 MHz. Geeignet für Zehntelwellenlängen unter der Frequenzgrenze bis 30 MHz.  
Preis: 19,90 DM (inkl. 10% MwSt.)

*The same rig was marketed in Europe by the importers Sommerkamp and sold as the FT-250*





## *The Yaesu FT200*

*Colin Guy G4DDI*

The Yaesu FT200 is an SSB/CW transceiver that covers the pre-WARC amateur bands from 80m to 10m. An almost all valve design that provides around 180watts PEP, good stability and a very good receiver that is a delight to use, even under today's band conditions.



The design first saw the light of day in the late 60's in a grey and silver case. It was also sold under the guise of the Sommerkamp FT250 (blue case) and the Henry Radio "Tempo One" (black and silver case, above). It had a short reincarnation in the early 70's in an all black case and was then sold as a cheaper alternative to the first FT101's. The accompanying FP200 AC power pack provided all necessary voltages from one transformer from 117 or 234 volt AC mains and included a front facing loudspeaker. A 12 volt power unit was also available for mobile use, this consumed 12 amps on receive and up to 27 amps on transmit - it was said that the mobile operator didn't need a separate heater in the vehicle...

I have recently seen nice examples of these for sale for less than £70 without the power pack, and £100 - £125 with. At this price they are an excellent buy, and when properly refurbished are a fully

competent HF radio, no bells and whistles but very easy to operate, stable, thanks to the solid state VFO, the receiver in particular is far better than many of the earlier solid state offerings from Yaesu, and I think it's a better performer than the KW2000. The tuning drive is a British made Jackson, and remains perfectly smooth in my 30 year old set. I have owned one from new (bought in 1973 from Western Electronics) and I have repaired many for other amateurs over the years. The following circuit description is adapted from the Yaesu manual.

### ***Circuit description.***

It can be seen from the block diagram that many sections are common for both receiving and transmitting. For an easier understanding of the operation, the receiving and transmitting sections will be described separately.

### ***Receiving Section***

Signal from the aerial terminal passes through aerial RX/TX relay via the input tuned circuit to grid 1 of RF amplifier valve V2, 6BZ6. Signal is amplified and via the next tuned circuit to the grid of receiver mixer V1, 6U8, pentode section. The local oscillator signal is applied to cathode of this mixer and the I.F. signal appears at mixer anode. The I.F. signal then passes through the 9 MHz crystal filter to the two stage amplifier V104, 6BA6, V103, 6BZ6 and thence to V102A, ½12AX7. This stage acts as a product detector, with the BFO signal applied to its cathode, when receiving CW and SSB. V102B, ½12AX7 functions as an anode detection type AGC amplifier. With no signal applied, anode current is zero with anode voltage zero. When signal is applied, anode current develops, resulting in a negative anode voltage which is applied through diode D103 to AGC line. The circuit provides suitable AGC characteristics of fast attack, slow decay for SSB and CW. The internal resistance of the diode is low in forward direction and high in reverse direction. AGC voltage is applied to the RF and IF stages so that a wide range of signal levels can be handled. Detector output is fed to a pulse limiter consisting of silicon diodes D101, D102, then via AF gain control, to V101, 6BM8 AF output to speaker or

headphones.

## ***Transmitting Section***

Output of carrier oscillator V106, 12AU7 is injected to first grid of V107, 7360 balanced modulator and audio signal from microphone amplifier to modulating grid of balanced modulator. Suppressed carrier double sideband is developed at the anode of the balanced modulator. This signal then passes through the crystal filter XF101, which eliminates one sideband, thus resulting in a SSB signal at the IF of 9 MHz. For AM transmission (sideband with carrier insertion) the balanced modulator becomes unbalanced because of the switching circuitry, permitting the carrier to pass through, and also the carrier frequency is shifted by means of a varicap diode circuit so that carrier passes freely through the filter pass band. Amount of carrier insertion level is adjustable by the AM carrier control VR8. For CW transmission, audio is disabled, and as for AM, the balanced modulator is unbalanced and carrier frequency shifted to allow full carrier to pass through filter. In the TUNE condition, a 1500 Hz signal from the audio tone oscillator TR503 is applied to the balanced modulator. This provides a convenient tuning signal near the filter centre frequency. The level of signal is controlled by the mic. gain control. The 9 MHz signal, after passing through the filter, is amplified by IF amplifier V104, 6BA6, thence to grid of the transmit mixer V4, 6EJ7, together with local oscillator signal. The resultant difference between these two frequencies appears at the anode tuned circuit of the mixer and is the transmitter output signal frequency. On the 14 MHz band, additive mixing is used. This signal is amplified by V5, 12BY7 tuned driver and finally to power amplifier V6/V7, 2 x 6JS6A, and to the aerial. Power amplifier V6/V7 operates in class AB2 for maximum power output. The AC audio component of PA grid current, when overdriven by signal peaks, is rectified by diodes D4/D5 to provide an ALC (Automatic Level Control) voltage to the IF amplifier stage thus reducing its gain and maintaining low distortion. The PA Pi network anode circuit provides attenuation to the higher order harmonics and enables easy, flexible adjustment of impedance matching to antenna feed line. On phone, PTT and VOX control is available. On VOX, a sample of signal from microphone is applied to grid of V8 and then to V9A, rectified by



diode D2, SH-1, producing a positive bias on the grid of V9B relay driver, causing anode current to flow and relay to actuate. On CW, straight or break-in keying methods are available. Break-in is produced by keying audio oscillator tone applied to VOX amplifier as well as transmitter bias line. The relay switches the bias on V107, V4, V5, V6 and V7. The tone signal also can be heard from speaker while keying, thus providing side tone monitoring.

## ***Oscillator circuits***

In the FT-200 crystal oscillators are used for carrier generation and the band switched heterodyne oscillator, together with a self-controlled oscillator for the VFO, which is at a frequency low enough to obtain good stability. Other oscillators included are 100 kHz crystal calibrator and audio tone oscillator. An external VFO model FV-200 is available to provide additional operational flexibility and split frequency operation:

### ***Carrier crystal oscillator***

V106, 12AU7 double triode with crystals 8998.5 kHz and 9001.5 kHz, one in each triode section. With sideband selector switch at NORMAL, carrier crystal 8998.5 is operative for 7 and 14 MHz band and 9001.5 for 3.5, 21 and 28 MHz. When the selector switch is in REVERSE position, then the carrier crystal oscillator sections are changed. The carrier oscillator is used as a BFO when in receive mode. On AM & CW, crystal 9001.5 is used and its frequency is lowered 200 Hz by diode switch D104, 1S1007, bringing the carrier into the filter pass band.



### ***Band switched heterodyne oscillator***

This is a crystal oscillator using silicon type 2SC372 transistor, and it is operative on bands 7, 21 and 28 MHz.

### ***VFO***



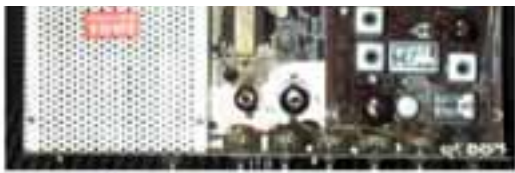

FT299 Top View

The VFO is a transistorized Colpitts circuit with 25C372 oscillator and 25C372 buffer. It has linear tuning over the range 5 to 5.5 MHz. A pass band filter circuit at output is tuned to pass the 5-5.5 MHz range. Varicap diode D401, 1S145 permits receiver off-set tuning (clarifier) of  $\pm 5$  kHz on receive.

### ***Crystal calibrator oscillator***

Transistor oscillator 2SC367 with 100 kHz crystal, and diode type 1S1007 harmonic generator provides accurate check points every 100 kHz on main dial.

### ***AF oscillator***

A phase shift oscillator using a 25C372 transistor, generating an audio tone signal at 1500 Hz, supplies transmitter tune-up signal and CW side tone monitoring. This oscillator also actuates the VOX relays for semi-automatic break-in CW operation.

### ***Local oscillator mixer circuit***

The VFO output is applied to grid 1 of V3, 6CB6 mixer and the heterodyne oscillator output to its cathode. The resultant beat frequency is selected in the anode tuned circuit.

### ***Meter circuit***

The meter is a 1 mA movement, and it is connected to 2nd IF stage to read the change in cathode voltage of V 103, resulting from variations of AGC voltage, to indicate receiver "S" units. The meter is automatically switched by relay RL101, on transmit, to indicate relative power output (P0) PA cathode current (IC) and ALC voltage. Meter scale is fully calibrated, and the transmitter metering functions P0, IC and ALC, are selected by panel mounted slide switch.

## ***Voltage regulator circuit***

The voltage regulator circuit, mounted on a print board, provides 9 volts for all transistor oscillators, the supply for this is derived from the +150V HT rail via a large 5KW resistor. Two transistors are used, 2SC372 and 2SC367, together with two zener diodes, 1S331 and 1S336, and voltage level can be set by adjustment of variable resistor VR501.

## ***Mixing sequence***

The 5 - 5.5 MHz VFO is mixed with the signal frequency on 80m, (3.5 - 4MHz) to give the 9MHz IF by addition, and on 20m (14 - 14.5MHz) by subtraction. On 40m the VFO is premixed with the band switched oscillator at 11MHz to give 16 - 16.5MHz, the signal frequency (7 - 7.5MHz) is subtracted to give the 9MHz IF. On 15m the VFO is premixed with 35.5MHz to give 30 to 30.5MHz, again subtracting the signal frequency (21 - 21.5MHz) gives the 9MHz IF. On 10m the premix frequencies are 42.5MHz, 43.0MHz, 43.5MHz and 44.0MHz to give ranges of 28 - 28.5MHz, 28.5 - 29MHz, 29 -29.5MHz and 29.5 - 30MHz respectively.

## ***Accessory Socket***

An accessory socket is provided for an external transverter etc. If no accessory is connected, a plug must be inserted with a link between pin 1 and 2 to supply heater voltage to the PA valves. The same applies to the external VFO socket.

## ***Power supply***



The FT200 requires a 12 volt AC supply for the valve heaters, which also supplies the relays via an internal rectifier, 150V DC and 300V DC for the valve anodes, 600V DC for the PA ***The VMARS Newsletter*** and -100 V DC bias supply.



The FP200 AC Power supply

All of these are supplied from the FP200 AC supply unit or the DC200 12 volt supply unit. None of the supplies require to be stabilized, and it would not be difficult to concoct a psu from a number of transformers if you acquire a set without a psu, or with one that is burnt out. The power and accessory socket (both 11 pin “octal” types) connections are shown in the diagrams at the end

of the article.

## **Construction**

The IF, Tx and RX audio stages and Tx mixer are all on a large PCB, this can be seen in the underside view below. The underside of the PCB is easily accessible for repair and should present few problems. Smaller pcb's carry the 9 volt regulator and tone oscillator, the 100kHz crystal calibrator and the band switched heterodyne oscillator. These are all mounted on a conventional steel chassis, the receiver RF stages, transmitter mixer, driver and PA and VOX amplifier are all directly mounted on the chassis and conventionally wired. The chassis and vertically mounted front panel can be extracted from the “wraparound” steel case by removing five screws from the underside. Once removed virtually everything is accessible for repair.

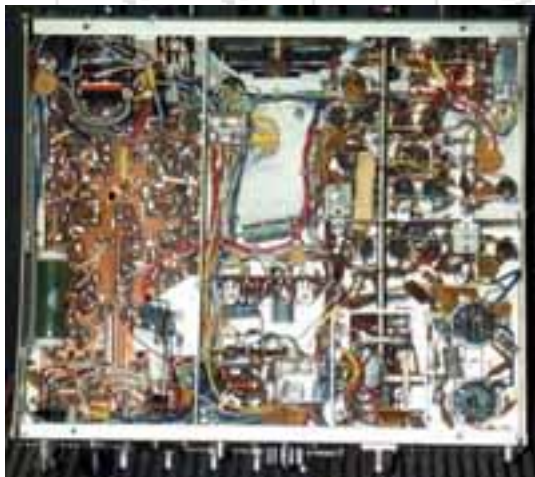

### **FT200 underside view**

#### ***What to look for when buying one.***

Considering the amount of heat these sets generate they are extremely reliable, there are, however, as with just about any piece of equipment, a few weak spots. Undoubtedly the most common fault is failure of the pa grid coupling capacitor C55, shown in the manual as 100pF 1kV, but I have frequently found 500 volt specimens fitted here. There is 300 volts on one side of it from the driver anode and minus 150 volts the other, plus several tens of volts of RF on transmit so it obviously has a hard time. Failure not



only removes the negative grid bias on the PA valves, but applies a positive bias to them. Not unnaturally this results in the rapid demise of the valves, which are now expensive and quite difficult to obtain, and can also result in the destruction of the mains transformer (protected only by a single primary fuse, often replaced with one of a higher rating!) if the owner wasn't there to switch the set off very quickly when it showed the obvious signs of distress. The FT101 and 901 also suffered from this problem. Therefore, a good look at the PA valves is essential, and if you are offered a power unit with it, a close look (and sniff) at the transformer is worthwhile. Another area worth a look is around the receiver audio output valve (V101, 6BM8) which is mounted on the main printed circuit board. This can suffer from any of the usual afflictions of a triode - pentode AF amplifier - leaky coupling capacitor.

### ***Issue 32***

(C103, 0.01mF), leaky or shorted cathode decoupling electrolytic (C101, 30mF 15V) or leakage in the valve itself. All of these cause the valve to run even hotter than normal with no apparent effect on performance, but it has the result that the PCB cooks to a cinder. In this case a prod of the valve will show that it is hanging in there only by the copper tracks! Both of these faults can be repaired, but it is worth looking, and allowing for in the purchase price. Also look at the RF section trimmers (visible through the holes in the bottom of the case) to see if they have been “twiddled” – ham-fisted adjustment of these can cause other problems – see below – and realignment is not a task to be taken lightly.

### ***Other faults.***

Not uncommon is an apparent lack of AGC action, with the receiver seeming insensitive and little movement of the s-meter even on very strong signals. This is usually because of grid leakage in one or other of the IF valves (V103, 6BZ6, V104 6BA6) upsetting the slightly unusual AGC circuitry. Substitution is the best way of determining this. A noisy band switch is not uncommon, lack of sensitivity on one band usually being traceable to this area. Do not be tempted to spray the switch with switch cleaner whilst the set is powered though, it can cause the wafers to arc as some carry full HT,



and replacement would be a serious job. Give the switches a spray with the power off, work the switch a few times then allow to dry before applying power. "Super Servisol" is recommended for this job, don't be tempted to use WD40! Total failure of one band can be caused by an open – circuit coil in the receiver RF or pre-mixer stages – these are all common to transmit and receive. What happens here is that the valve anode voltage is supplied via the coil and the tuning gang and trimmer are connected from the anode to earth, so the HT voltage is across both, a short in the gang section or the trimmer, caused by stray metal particles or inept handling burns out the coil. Remember that a jumper plug must be in the accessory socket – if you have no transmit output look to see if the PA valve heaters are alright!

## Valves

V1	6U8, ECF82
V2	6BZ6
V3	6CB6
V4	6EJ7
V5	12BY7A
V6	6JS6A
V7	6JS6A
V8	6AV6
V9	12AU7, ECC82

The only valve that is getting scarce today is the 7360 balanced modulator, but I've never known an instance of failure of these, so as long as your set has one, and it isn't broken there should be no problem. The PA valves, 6JS6, can still be obtained in matched pairs though expensive. These do seem to lose emission over time, this probably happens if the set is used for long periods of receiving and little transmitting, as the heater remains on all the time, there is no facility to switch them off as there is with the FT101 etc. All of the other types are fairly common and easily obtainable. The table below shows the complete valve list, with British equivalents where known.

- V101 6BM8, ECL82
- V102 12AX7, ECC83
- V103 6BZ6
- V104 6BA6, EF93
- V105 12AX7, ECC83
- V106 12AU7, ECC82
- V107 7360

**FT200 Valve lineup**

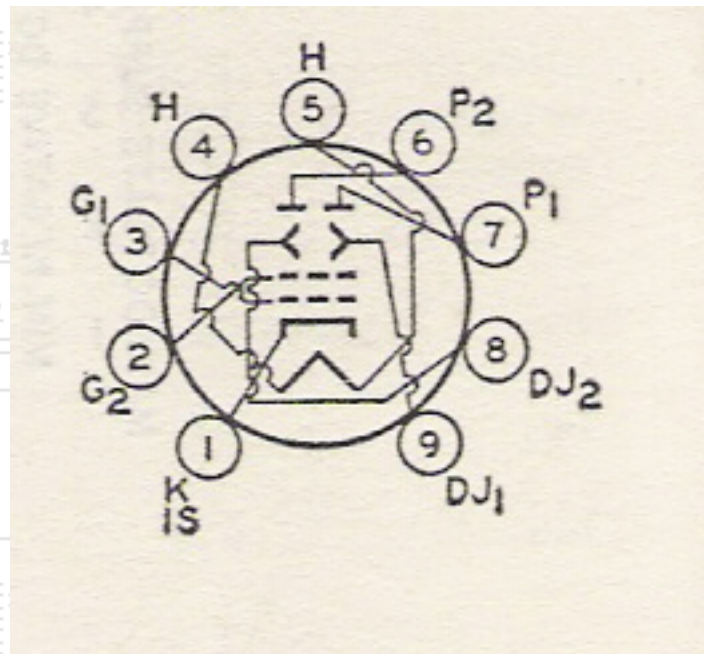
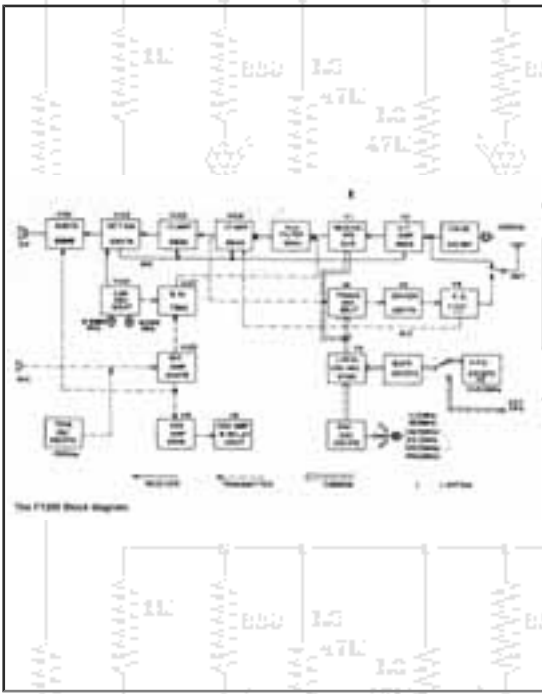

**Semiconductors**

There are no exotic semiconductors or unobtainable IC's (as there is with the FT101!) All of the

transistors are small signal NPN types and should be easily replaceable if necessary, though I've never known one to fail. The numerous diodes shouldn't present a problem, the only ones I've had trouble with have been the power supply rectifiers, which can be replaced by easily available BY227, 1N4007 etc.

**Microphone socket** A ¼ inch stereo jack plug is used for the microphone, slightly unusually the tip is the PTT connection and the ring is the mic live. The sleeve is of course earth.

**Alignment CAUTION** —Before any work is attempted, remember that high voltages are employed in this equipment, so —TAKE CARE! Equipment required:

VTVM with RF probe

RF standard signal generator

AF signal generator

Frequency meter

Dummy load 50 ohms

Suitable alignment tools

### ***Voltage regulator***

The V.R. is mounted on a printed circuit board and supplies a regulated output of 9V, adjustable by the pre-set type miniature pot VR501. If output cannot be brought up to the 9V, level it may be due to a fault in components on the printed circuit board, e.g. transistors or zener diode, or supply voltage below 11V.

### ***VFO alignment***

On the red scale, "0"=5 MHz and "500" = 5.5 MHz Switch off crystal heterodyne oscillator by placing band switch on 3.5 or 14 MHz band. Set the receiver offset tuning OFF.

Use frequency meter for alignment, although this can be done, with care, if beats are heard every 100 kHz using the crystal calibrator. Coarse alignment is by adjustment of trimmer TC401. The piston type trimmer TC402 is for adjustment of temperature compensation. If turned clockwise, then compensation becomes greater. If TC402 is adjusted, then TC401 must be re-adjusted to maintain calibration. For precise adjustment of dial linearity, careful adjustment (by bending) of end rotor plates of main tuning condenser is necessary. VFO injection to grid 1 of V3, 6CB6 should be 0.5V or more over full VFO range, measured with VTVM and RF probe. To obtain the same frequency of clarifier at "0" as at "OFF", adjust VR7.

### ***Heterodyne crystal oscillator***

Apply RF probe to Pin 2 of V3, and with band switch at 28.5, adjust L202 for maximum meter reading. On 21 MHz band adjust TC202. On 7 MHz band adjust TC201. If optional 10 meter range crystals are fitted, adjust appropriate trimmer condensers for 10 meter crystals.

**100 kHz calibrator** Adjust frequency with TC301 by checking against WWV, with aid of separate receiver.

**Pre-mixer (VFO mixer)** This is V3, with output anode tuned circuit to select the resultant beat of VFO and heterodyne oscillator (or VFO frequency in case of 3.5 and 14 MHz bands). This alignment should be carefully done as other frequencies can appear at output, VFO, etc. This alignment is explained in transmitter alignment section. Refer to chart, below, for correct output frequencies.

### ***Balanced modulator***

Band	Mixed Frequency
3.5	5 – 5.5 MHz
7.0	16 – 16.5 MHz
14.0	5 – 5.5 MHz
21.0	30 – 30.5 MHz



**28.0 37.0 – 37.5 MHz**

**28.5 37.5 – 38 MHz**

**29.0 38 – 38.5 MHz**

**29.5 38.5 – 39 MHz**

**V3 anode alignment  
frequencies**

## **AGC**

Set function switch to AM, RF gain maximum, then S-meter should read "0" with the aerial socket shorted. Set VR102 (AGC adjust) so that it is at a point just before the S-meter needle commences to rise above "0". Now adjust the meter sensitivity control so that with 50mV applied to the aerial socket from the signal generator the meter reads S9. Now set function switch to SSB, short out antenna socket, and meter should read "0"; but if not, then adjust the compensation capacitance (C165) between pin 2 and pin 8 of V102 to make meter read minimum deflection.

## **I.F. amplifier**

Connect signal generator at 9,000 kHz and adjust tuning for maximum S-meter reading at centre of filter pass band by observing S-meter at same time as tuning signal generator frequency. Now adjust L101, L102, L103, L104 for maximum meter reading.

## **Receiver mixer**

This is V16U8 (alternative types 6EA8, 6GH8). Connect RF probe to pin 8, cathode of triode section, and adjust grid tuning. Oscillator injection should read greater than 0.5V on every band. Adjust trap coil L22 for minimum beat at 21.3 MC. This adjustment should occur within one turn of the core slug. L1 is trap coil for 3.5 and 14 MC bands and should be adjusted so that no oscillation occurs in these bands. Use a plastic alignment tool so that no damage will result to the internal hexagon type slugs.

## ***RF amplifier***

Connect signal generator to aerial socket. On 3.5 MHz band set VFO to "0" on black scale and GRID to second point up from its anticlockwise position. Apply 3500 kHz signal and adjust L7 and L12 for maximum S-meter reading. Use plastic alignment tool. 7 MHz band, VFO to "0" on red scale, GRID at same point as for 3.5 MHz, signal generator at 7000 kHz. Adjust TC1 and TC2 for maximum. 14 MC band, VFO to 250, GRID at centre position, signal generator at 14250 kHz. Adjust L10 and L15 for maximum. 21 MHz band, VFO to 250, GRID at centre, signal generator at 21250 kHz. Adjust L9 and L14 for maximum.

28.5 MHz band, VFO to 500, GRID at centre, signal generator at 29,000 kHz. Adjust L3, L8 and L13 for maximum. On 7 MC band, VFO to 500, apply 9 MC signal of sufficient level to give an S-meter reading; then adjust L2 for minimum dip in S-meter reading.

## ***Transmitter Alignment***

The transmitter uses many common receiver circuits; therefore it is necessary to first correctly align the receiver section. A 50-75 ohms dummy load must be used on the transceiver during transmitter alignment. Take care to avoid touching high voltage points!

Function switch to TUNE, meter to P.O., tune transmitter for maximum reading. (Keep IC down by use of MIC gain). Now function to SSB, MIC gain to zero, and adjust VR106 for minimum reading. For most sensitive indication, connect RF probe to dummy load, or use another receiver and observe its S-meter reading. Then switch to opposite sideband position, and readjust VR106. Repeat several times for best result. If there is a marked difference between the two positions, then adjustment of carrier oscillator or crystal filter may be required.

## ***Crystal filter***

The filter is aligned once in receiver alignment, but further alignment in this section (transmitting) is

necessary. At the TUNE position adjust L103, L104 and L105 for maximum output. Keep drive reduced to a fairly low level for the most accurate determination of the maximum peak. In order to examine filter characteristics, set function to SSB and connect an A.F. generator to MIC jack, then take a curve of the A.F. response (in effect, the filter pass band), by plotting between 300-2500 Hz. If output level changes no more than 3 dB, then it is OK. Repeat on reverse sideband. If the two curves do not match, then a slight adjustment of each carrier crystal frequency is necessary to bring the two curves together in their frequency limits. If carrier is too close to 9000 kHz filter centre frequency, then high audio frequencies will be attenuated. If carrier is too far removed, then low frequencies will be attenuated. Carrier frequency adjustment is by TC101 and TC102.

### ***Driver stage***

Set up transmitter on TUNE, but keep level down to safe limit by adjustment of MIC gain control; then adjust driver coils and trimmer condensers for peak in output, as in receiver section alignment.

### ***Final Amplifier Neutralization***

When replacing the final amplifier valves, it may be necessary to reset the bias to give correct idle current and check neutralization. Using the procedure outlined below will guarantee maximum output and long tube life. CAUTION HIGH VOLTAGES ARE PRESENT ON UNDERSIDE OF CHASSIS AND INSIDE OF FINAL COMPARTMENT. USE GREAT CARE WHILE MAKING ADJUSTMENTS WITH WIRING EXPOSED. Connect a dummy load to antenna, and set meter to IC. (cathode current.) Locate TC3, the neutralization variable capacitor shaft in the final amplifier compartment. Check final amplifier idle current in USB or LSB position and adjust as described before. Tune up the transceiver at 21.5 MHz, with MODE switch set to AM position, and advance CARRIER potentiometer or the rear panel until meter IC reads 150mA Rotate PLATE tuning control and observe dip as indicated on the meter. If the dip is not prominent, reduce loading control slightly for better indication. As the PLATE control is rotated the meter should rise equally and smoothly on either side of maximum dip indication.

Determine which side of the dip rises abruptly. Set PLATE control slightly to this side of dip keeping the meter reading below 150 mA. Using an insulated trimming tool, rotate the neutralization capacitor shaft very slightly in the direction which reduces the current shown on the meter. Repeat steps 6 and 7 until the meter indicates a smooth and equal rise on either side of the maximum dip point. The final compartment cover must be in place to supply the RF shielding required during the neutralization procedure.

## Operation

The transceiver is controlled by a three position lever switch which is marked "oper", "rec" and "cal". In the "rec" position the transmitter is disabled. Receiver operation is as simple as selecting your band and mode, and peaking the "Grid" control for maximum. Moving the switch to "oper" will put the transceiver into the transmit condition. If the mode switch in "tune", the carrier output can be controlled with the mic gain control, apply the minimum necessary to produce some output then dip the PA current in the normal way, keeping it below 150mA. If the mode switch is in CW, transmission is controlled by the key, and on SSB or AM, transmission is controlled by the PTT switch. Note that on SSB or AM, if the mic is unplugged the set will go to transmit immediately. The PA is tuned up in the normal way with the mode switch in the "tune" position, but care should be taken that it is coupled into as near as 50W as possible, the loading capacitor is very closely spaced and prone to arcing.

## Accessory socket connections

1. 6JS6A Heater
2. 12.6V Heater supply
3. +150V
4. +300V
5. +600V
6. -100V
8. Earth
9. Relay close on Tx
10. Relay common
11. Relay close on RX



## 7. ALC input.

### Conclusion

This is a highly useable radio that can be obtained quite cheaply, is generally easy to repair, and whose performance meets modern standards if properly set up. The only real downside of it is that it lacks top band (and the other "WARC" bands), the AM performance is poor - the filter is too narrow for receive, and the transmit quality is poor, being in reality SSB with reinserted carrier, and it takes some juggling with the mic gain and carrier level to get acceptable results. Performance on SSB and CW is excellent, drift is minimal after about 10 minutes warm-up, and the controls are few and mostly intuitive to use. On - air reports on SSB are always good and the receiver has a very low background noise level, no noticeable sprogies, even on 40m, and sounds excellent. There is not room to print the full circuit diagram in the newsletter, it spreads across four pages, but if anyone needs a copy please contact the author.

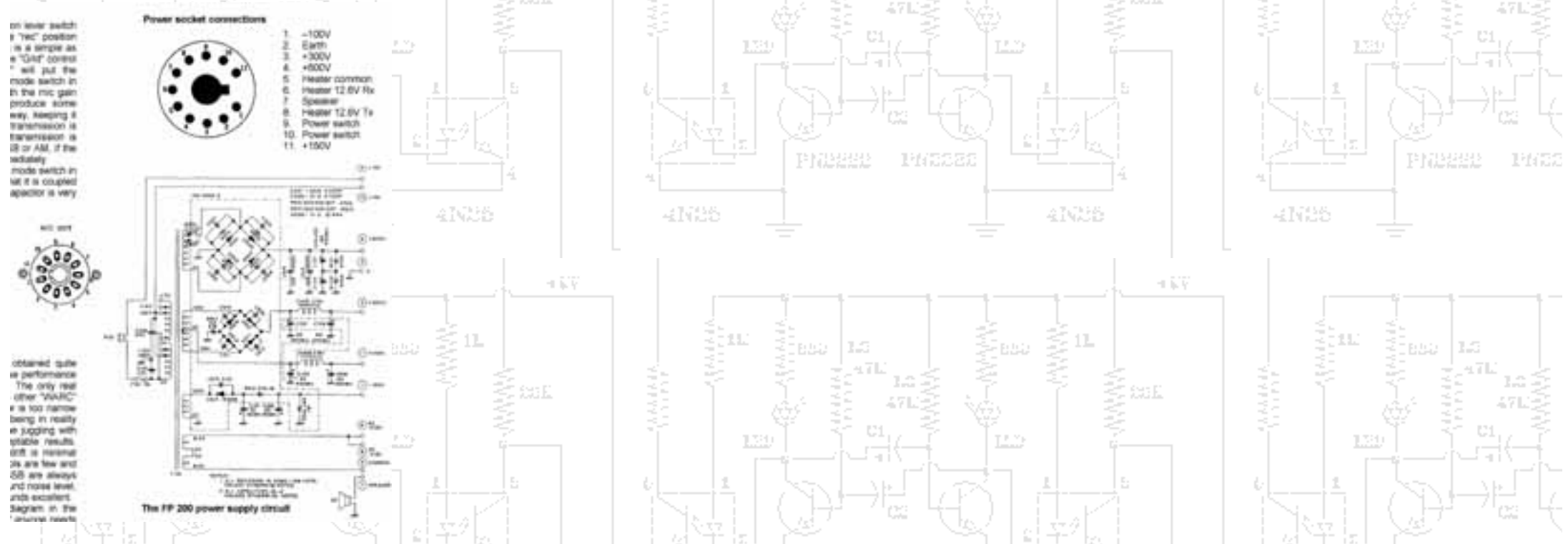

**[FT-200 FT-250 Henry Radio Tempo One](#)**  
**[FT-200 FT250 Tempo One Manual Free Down load](#)**  
**[Owners operators manual for \(VFO\) FV200 / Tempo FV/One](#)**



**For more information about the FT-200, Tempo One support your club!  
Check out the FT-200 club CD**

**["ZL" FT-200 Newsletters, FT-250, Tempo One CD ROM](#)**

**[Subscribe to the Fox Tango](#)**  
**[FT-200, FT-250, Tempo One Forum Here](#)**

**[Subscribe to FT-200, FT-250 Tempo One Forum Here](#)**

enter email address



***YOU ARE CORDIALLY INVITED TO JOIN US.***

Powered by [groups.yahoo.com](http://groups.yahoo.com)

